

SOME LIKE IT HOT, SOME LIKE COLD, SOME LIKE IT MILD BUT OLD
Chemical modelling of (exo)planetary atmospheres

Éric HÉBRARD

Department of Physics and Astronomy
University of Exeter



SOME LIKE IT HOT

Chemical modelling of (exo)planetary atmospheres

Éric HÉBRARD

Department of Physics and Astronomy
University of Exeter



SOME LIKE IT

Chemical modelling of (exo)planetary atmospheres

Éric HÉBRARD

Department of Physics and Astronomy
University of Exeter



CHEMICAL DIVERSITY OF (EXO)PLANETARY ATMOSPHERES

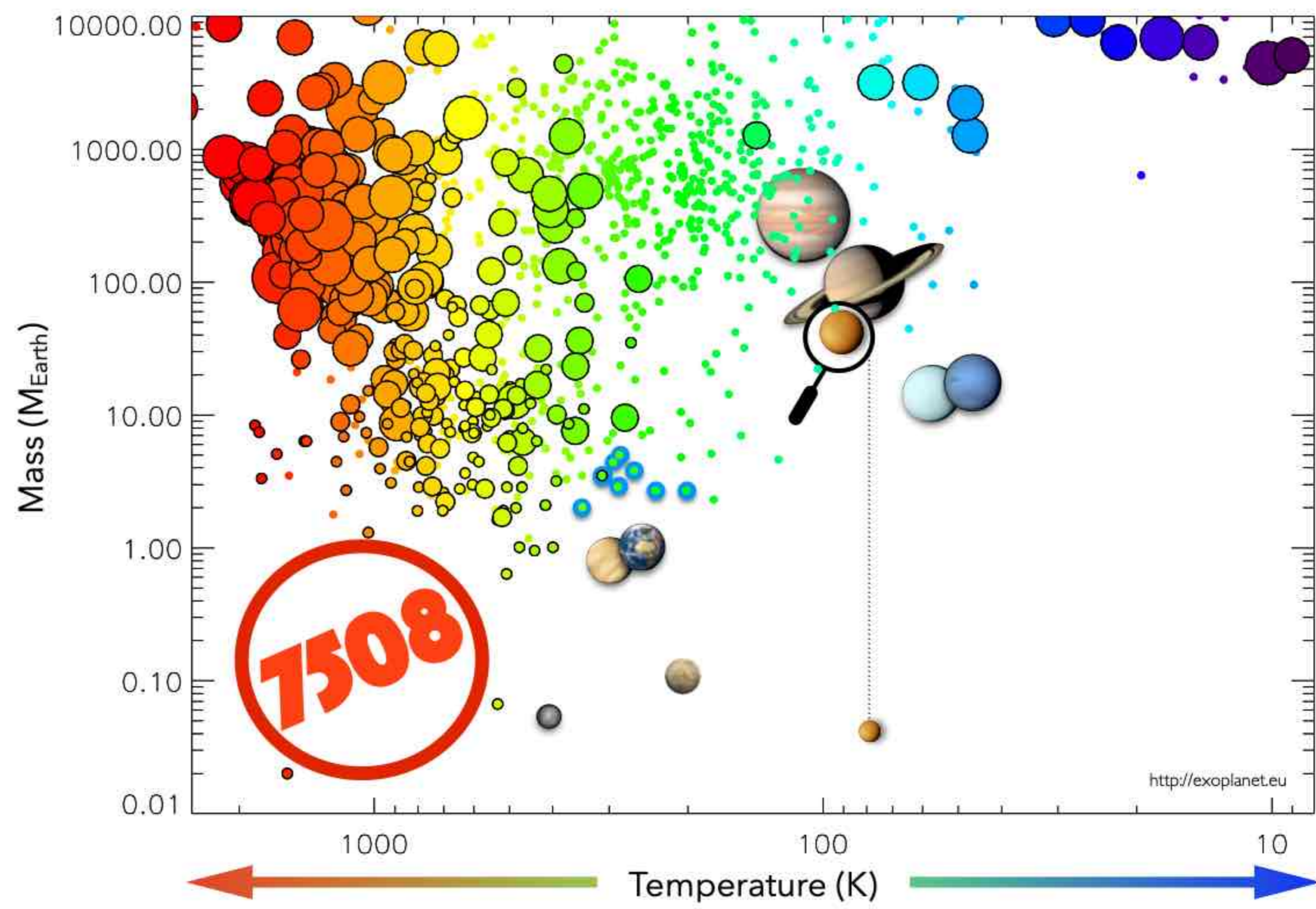

CHEMICAL DIVERSITY OF (EXO)PLANETARY ATMOSPHERES

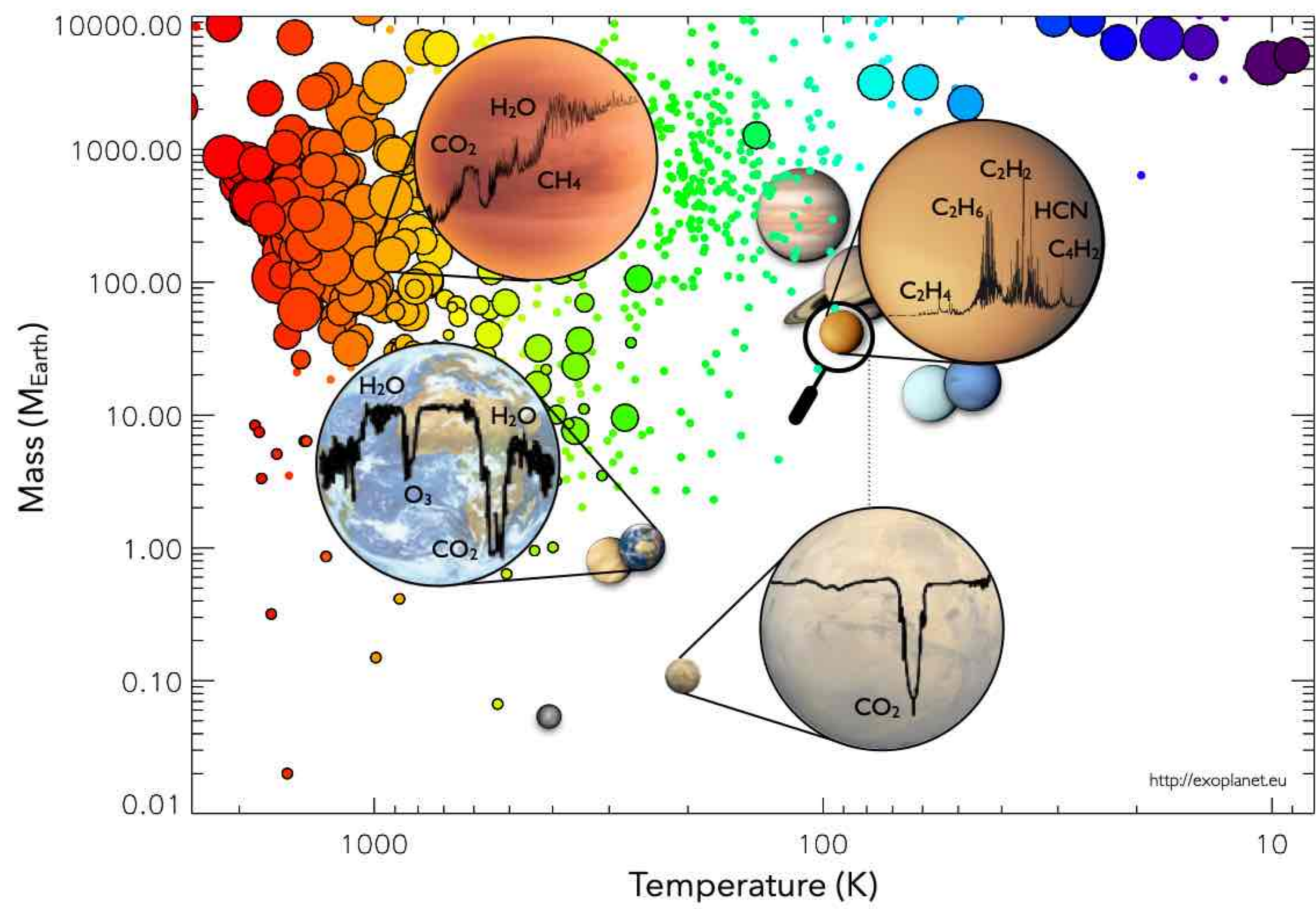

CHEMICAL DIVERSITY OF (EXO)PLANETARY ATMOSPHERES

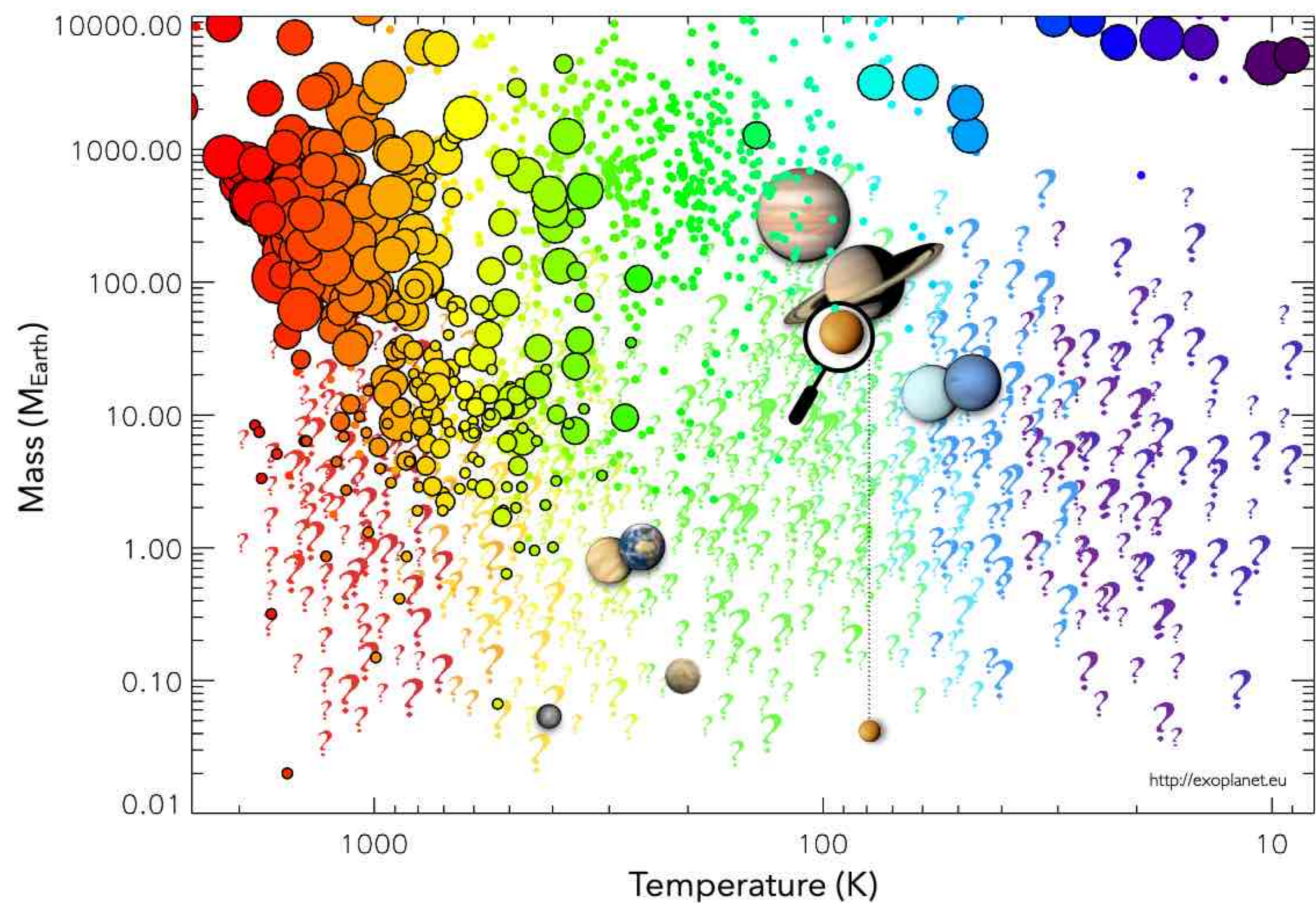

JWST - 2022

NGRST - 2027

E-ELT - 2029

ARIEL - 2029

HWO - 2040?

MOTIVATION

Secondary eclipse/direct imaging

Temperature structure, chemical composition, wind speeds

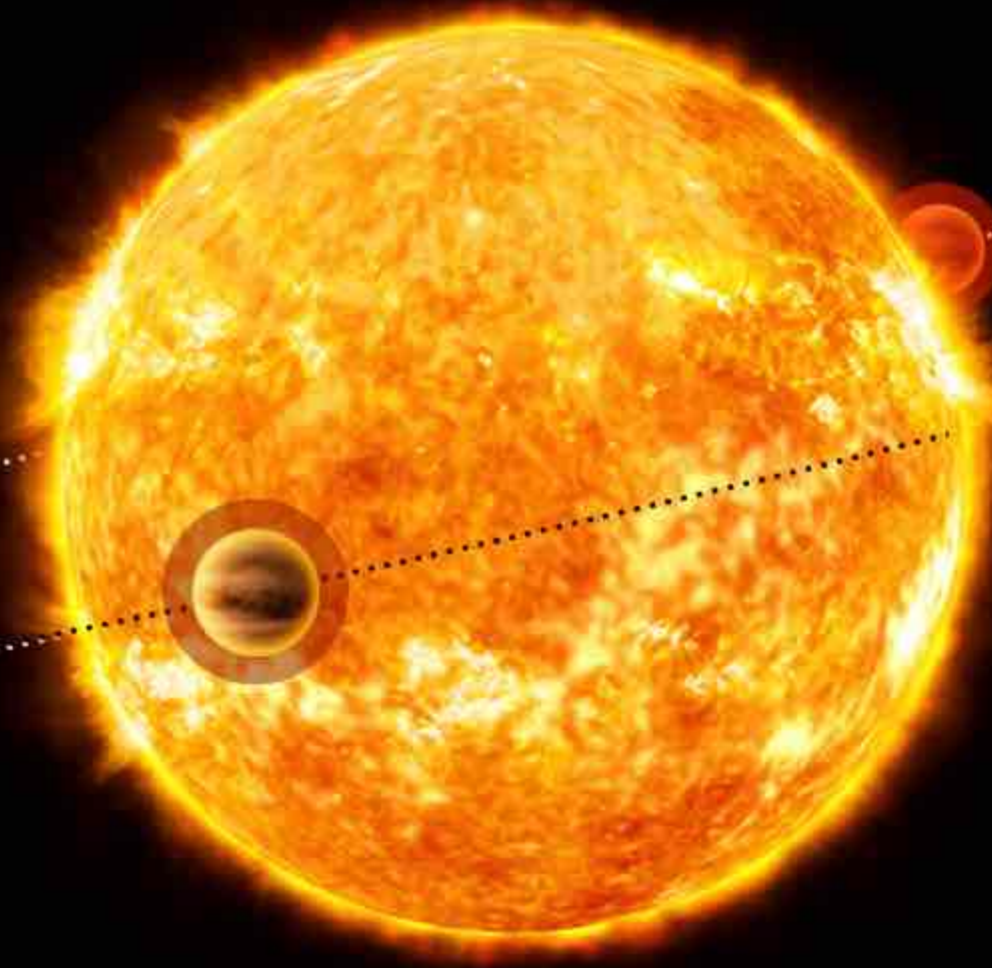

Phase curve

Dynamics, chemical composition

Primary eclipse

Chemical composition, haziness+cloudiness

CHEMICAL DIVERSITY OF (EXO)PLANETARY ATMOSPHERES

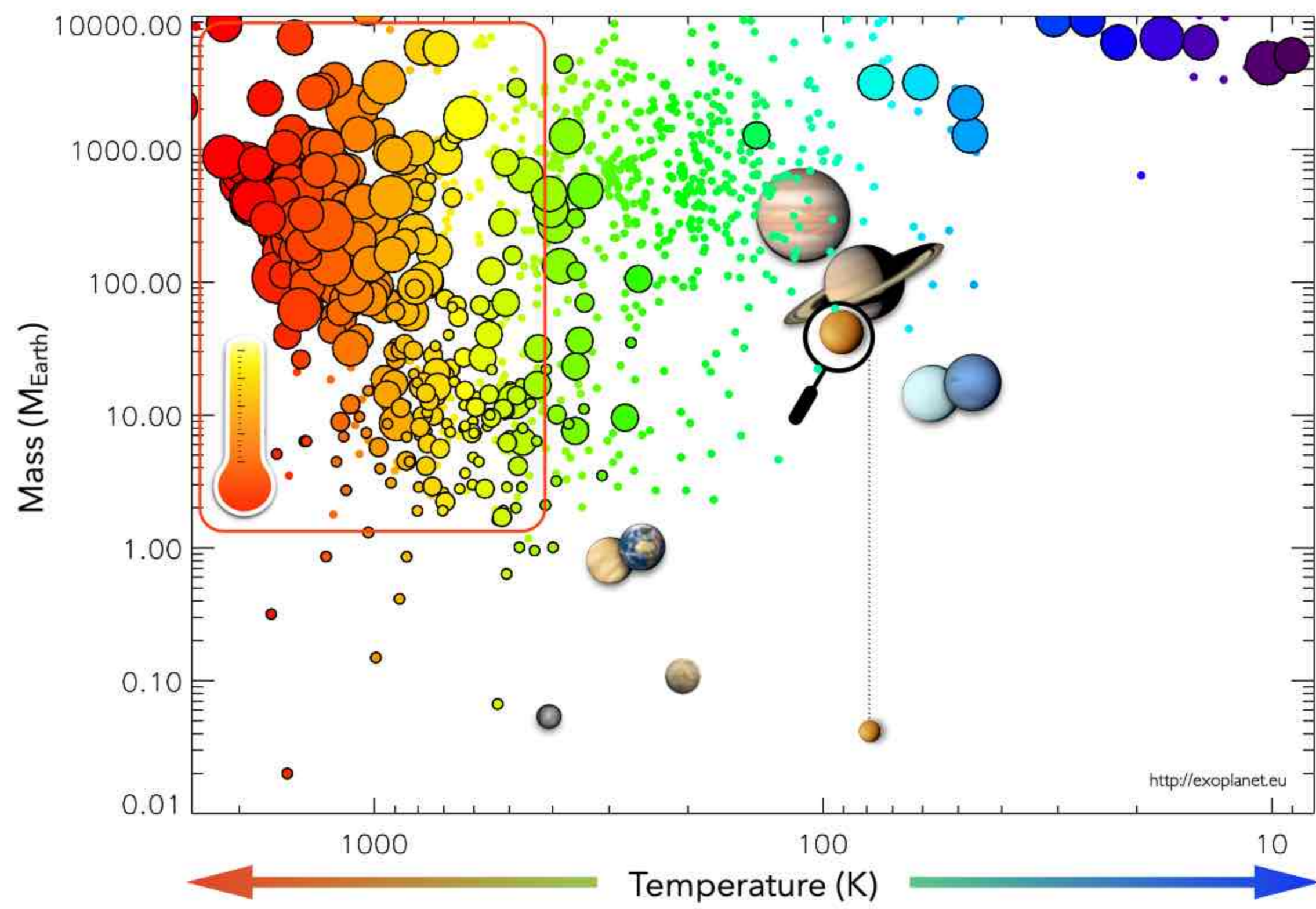

HOT JUPITERS / WARM NEPTUNES

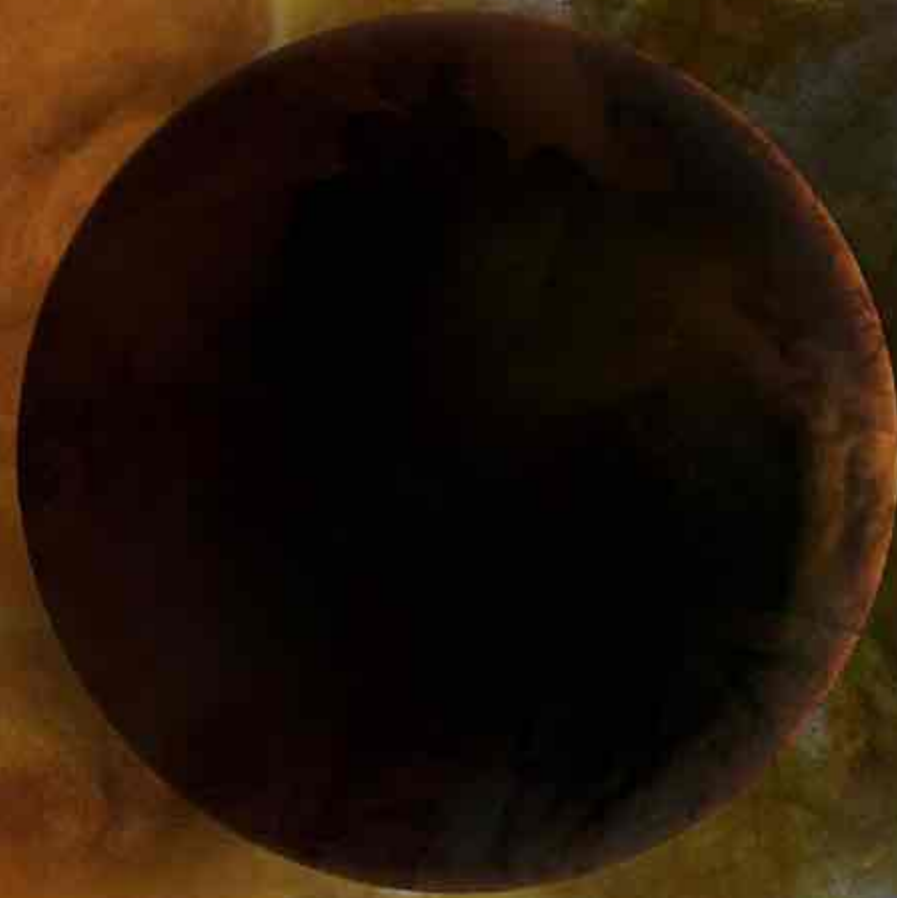

- Hydrogen-dominated gas-giants
- Short orbital period, < a few days
 - × high temperatures, > 1000 K
 - × tidally-locked

OBSERVATIONAL CONSTRAINTS

Atmospheric Composition

Na	e.g. Charbonneau et al. (2001)	K	e.g. Sing et al. (2011)
H₂O	e.g. Tinetti et al. (2007)	CH₄	e.g. Swain et al. (2008)
CO₂	e.g. Swain et al. (2008)	TiO	e.g. Désert et al. (2008)
VO	e.g. Désert et al. (2008)	CO	e.g. Snellen et al. (2010)
He	e.g. Spake et al. (2018)	SO₂	e.g. Ahrer et al. (2023)

High-resolution spectroscopy

e.g. Snellen et al. (2010), Wyttenbach et al. (2015), Louden & Wheatley (2015), Brogi et al. (2016)

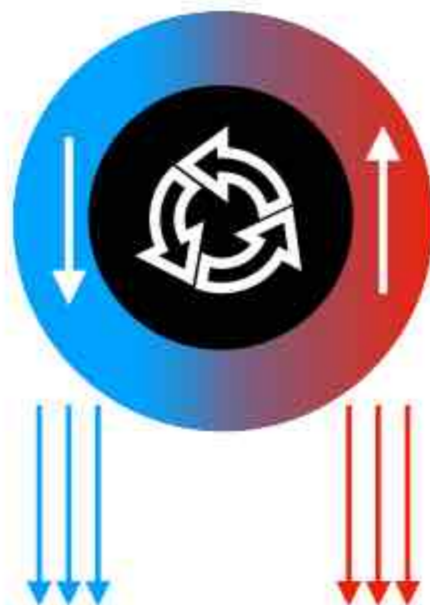

Atmospheric winds \sim kms⁻¹

Emission phase curve

e.g. Harrington et al. (2006), Knutson et al. (2007, 2009, 2012), Zellem et al. (2014), Wong et al. (2016)

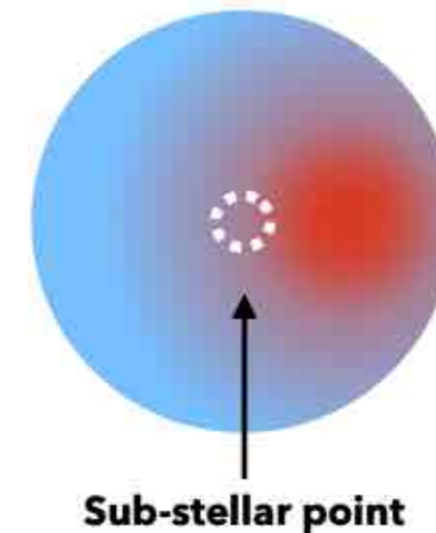

Offset peak emission > Shifted hot spot

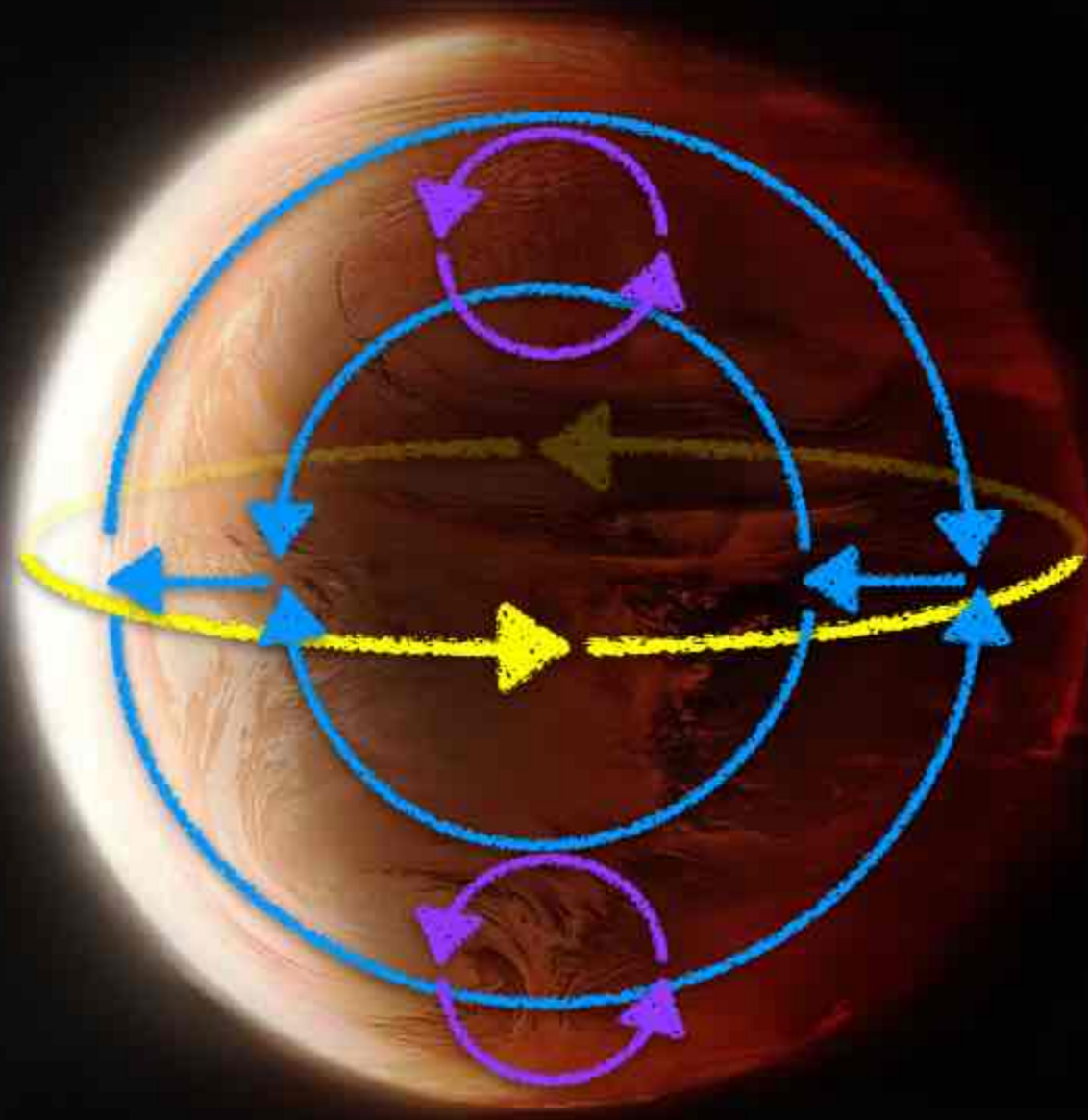

Jet: day-to-night circulation

Overturn: deep-to-shallow circulation

Gyres: traps

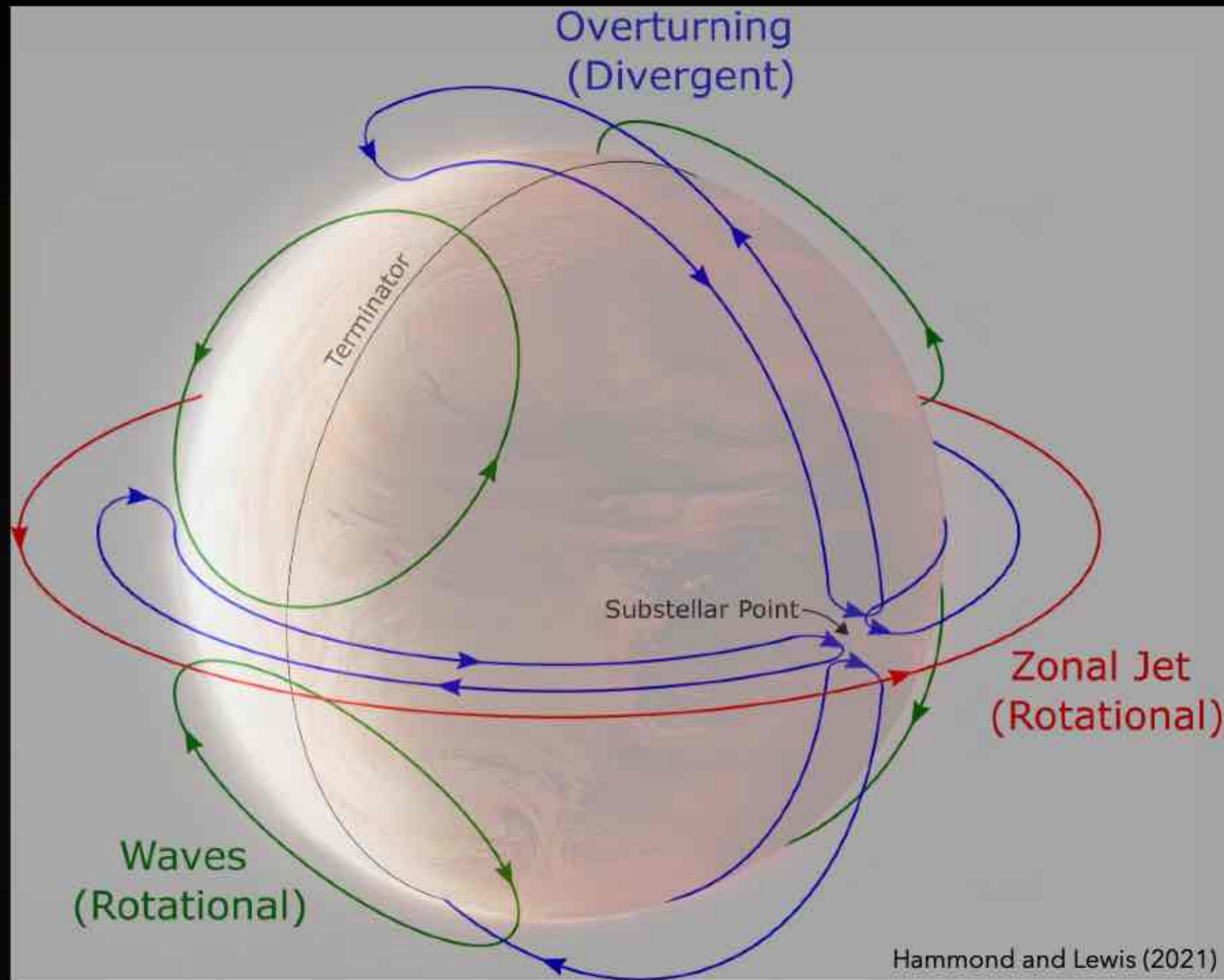

(EXO)CLIMATE SIMULATIONS

Met Office Unified Model

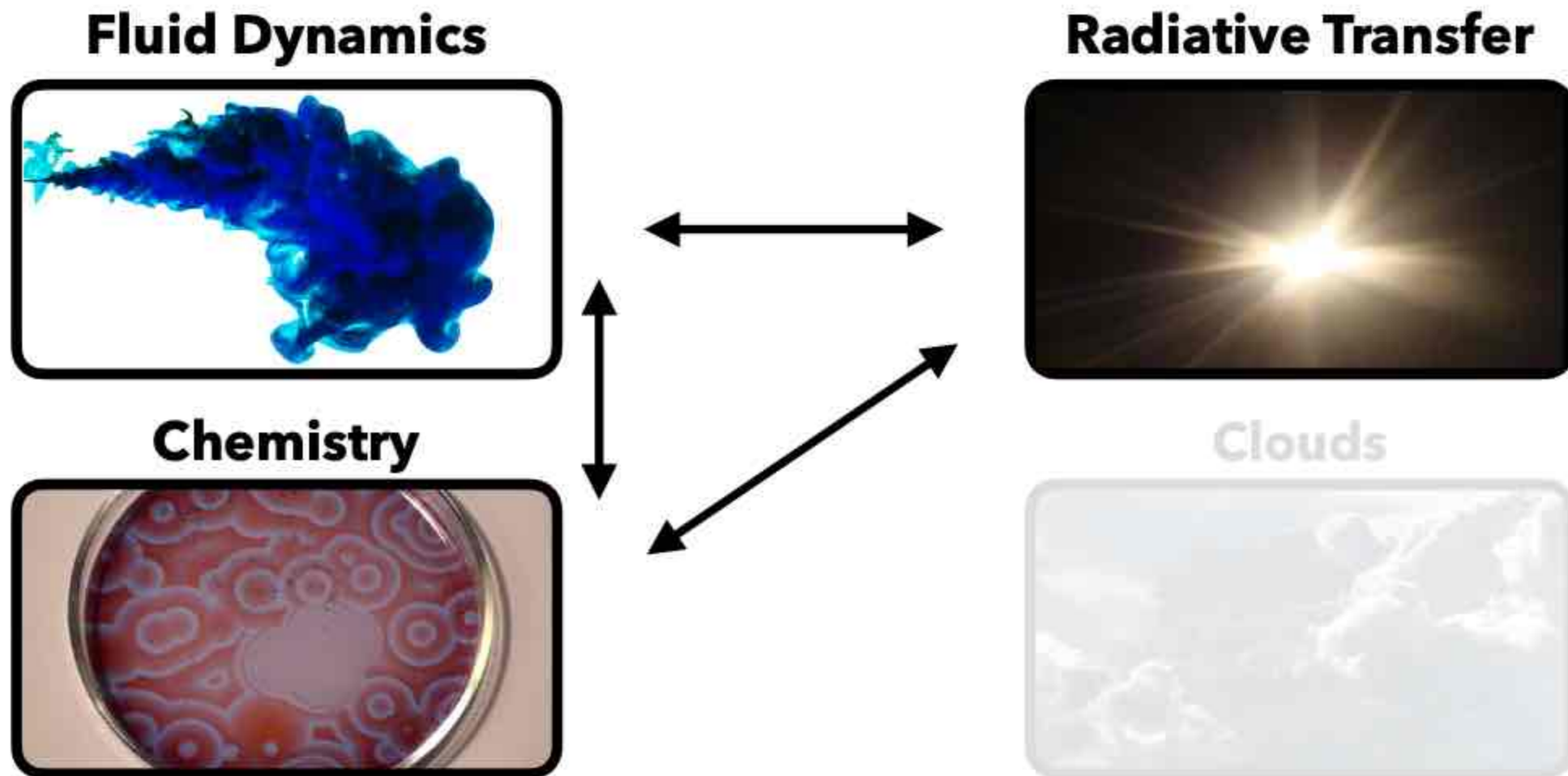

Lines et al. (2018a, 2018b, 2019), Christie et al. (2021, 2022)

(EXO)CLIMATE SIMULATIONS

Met Office Unified Model

Fluid Dynamics

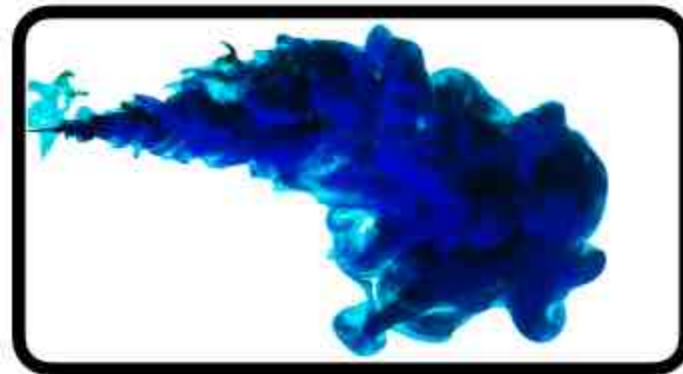

ENDGame dynamical core

Primitive <> Full

Benchmarked for HJ-like dynamical regime

Mayne et al. (2014, 2019)



$$\frac{\partial u}{\partial t} + \frac{u}{r \cos \phi} \frac{\partial u}{\partial \lambda} + \frac{v}{r} \frac{\partial u}{\partial \phi} + w \frac{\partial u}{\partial r} = \frac{uv \tan \phi}{r} - \frac{uw}{r} + 2\Omega v \sin \phi - 2\Omega w \cos \phi - \frac{c_p \theta}{r \cos \phi} \frac{\partial \Pi}{\partial \lambda}$$

$$\frac{\partial v}{\partial t} + \frac{u}{r \cos \phi} \frac{\partial v}{\partial \lambda} + \frac{v}{r} \frac{\partial v}{\partial \phi} + w \frac{\partial v}{\partial r} = -\frac{u^2 \tan \phi}{r} - \frac{vw}{r} - 2\Omega u \sin \phi - \frac{c_p \theta}{r} \frac{\partial \Pi}{\partial \phi}$$

$$\delta \left[\frac{\partial w}{\partial t} + \frac{u}{r \cos \phi} \frac{\partial w}{\partial \lambda} + \frac{v}{r} \frac{\partial w}{\partial \phi} + w \frac{\partial w}{\partial r} \right] = \frac{u^2 + v^2}{r} + 2\Omega u \cos \phi - g(r) - c_p \theta \frac{\partial \Pi}{\partial r}$$

$$\left[\frac{\partial \rho}{\partial t} + \frac{u}{r \cos \phi} \frac{\partial \rho}{\partial \lambda} + \frac{v}{r} \frac{\partial \rho}{\partial \phi} + w \frac{\partial \rho}{\partial r} \right] = -\rho \left[\frac{1}{r \cos \phi} \frac{\partial u}{\partial \lambda} + \frac{1}{r \cos \phi} \frac{\partial (v \cos \phi)}{\partial \phi} + \frac{1}{r^2} \frac{\partial (r^2 w)}{\partial r} \right]$$

(EXO)CLIMATE SIMULATIONS

Met Office Unified Model

Fluid Dynamics

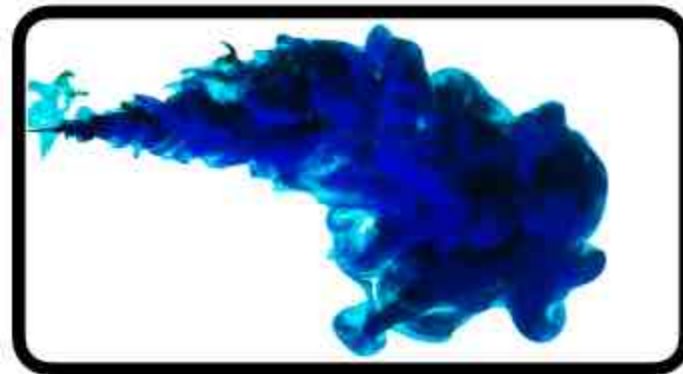

ENDGame dynamical core

Primitive <> Full

Benchmarked for HJ-like dynamical regime

Mayne et al. (2014, 2019)

Radiative Transfer

Met Office SOCRATES RT scheme

Two-stream, correlated- k , random overlap

Amundsen et al (2014, 2016, 2017) + James Manners

Now also used in: ROCKE-3D (Way et al. 2017, 2018), ISCA (Vallis et al. 2018)



(EXO)CLIMATE SIMULATIONS

 Met Office Unified Model

Radiative Transfer



**Accurate radiative transfer is crucial
for atmospheric heating rates
and thermal evolution**

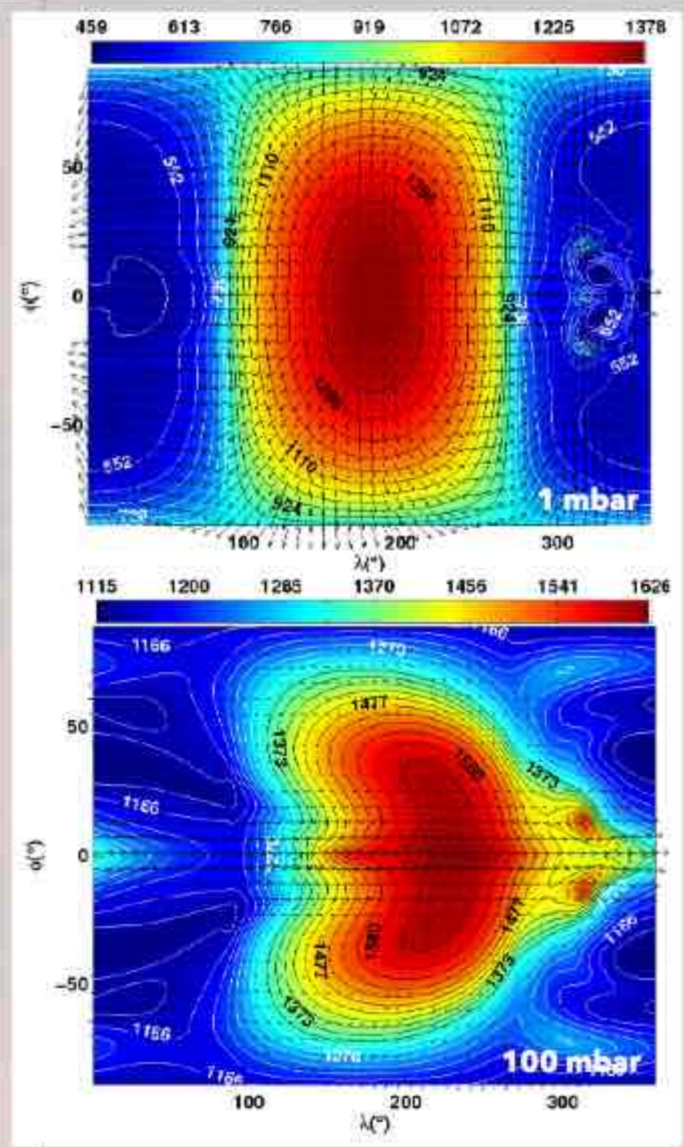
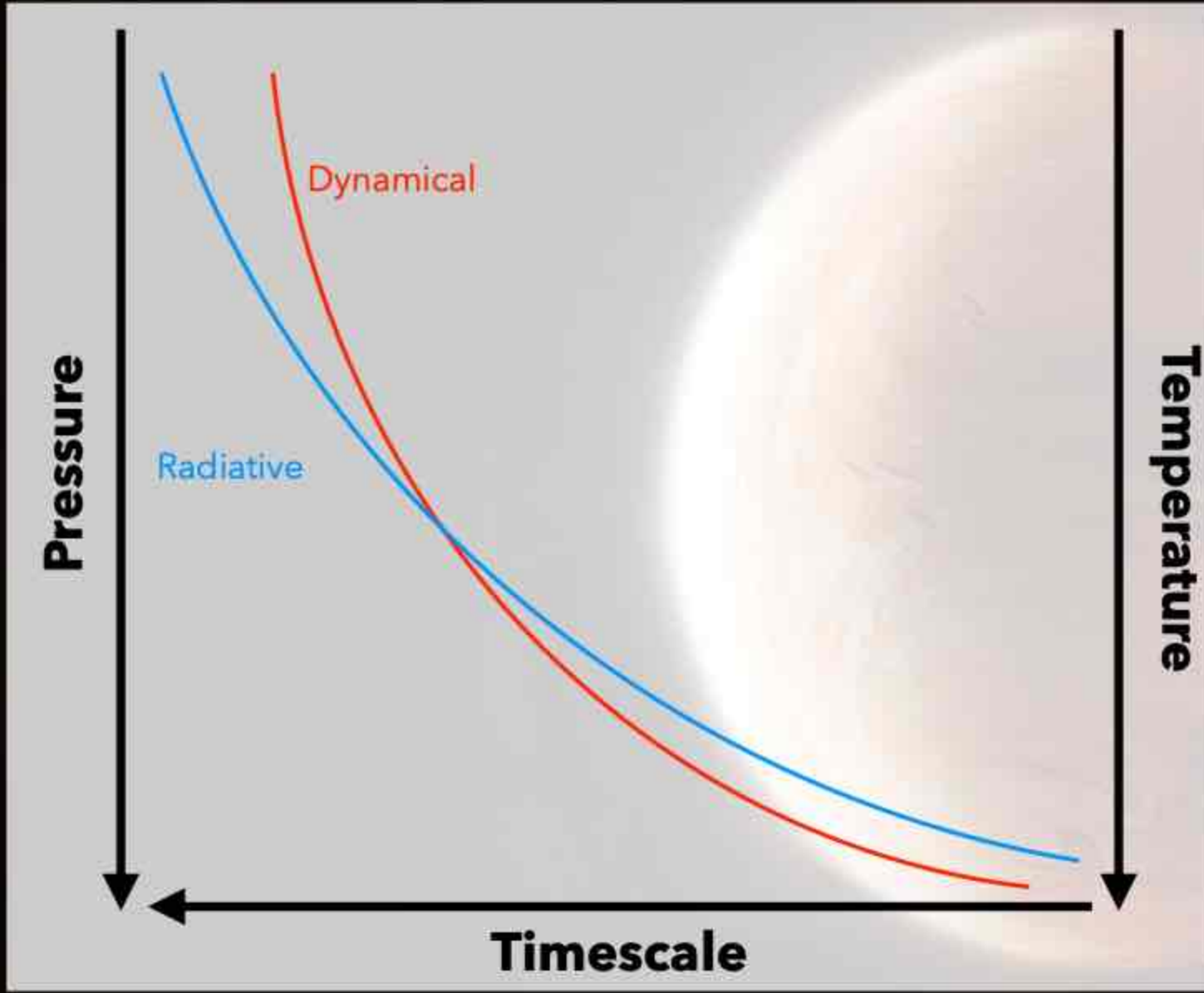

(EXO)CLIMATE SIMULATIONS

3D large-scale circulation, thermal structure and composition

Fluid Dynamics

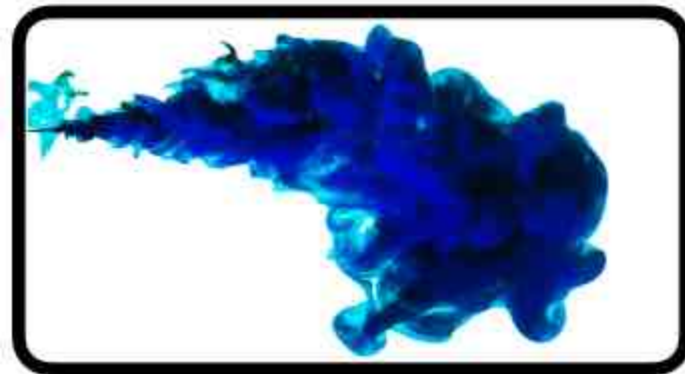

Radiative Transfer

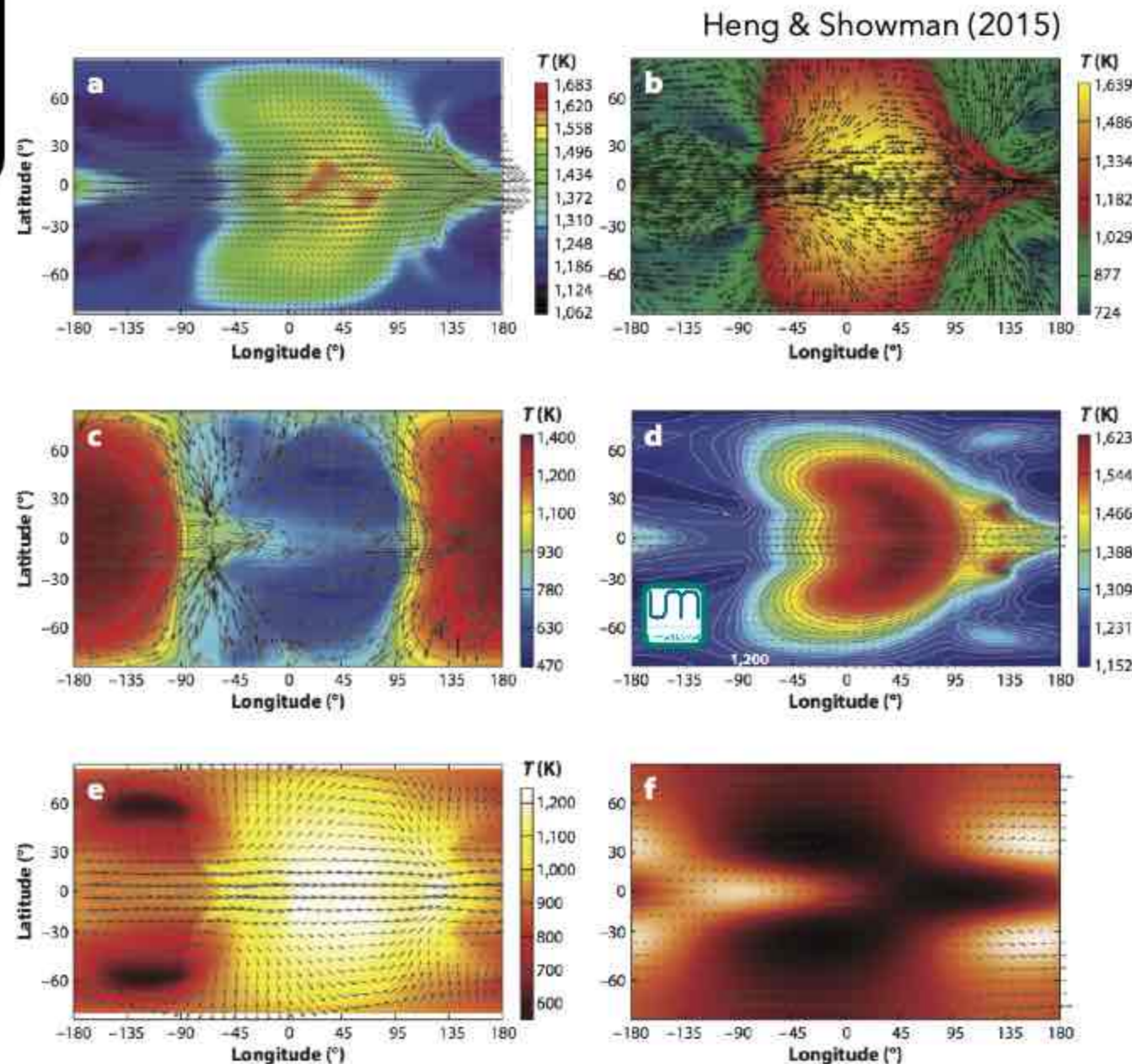

General Circulation Models (GCMs) applied to exoplanets

Showman & Guillot (2002), Dobbs-Dixon & Lin (2008), Showman et al. (2009), Menou & Rauscher (2009), Burrows et al. (2010), Heng et al. (2011), Mayne et al. (2014), Polichtchouk et al. (2014), Charnay et al. (2015), Amundsen et al. (2016), Mendonça et al. (2016), Hammond & Pierrehumbert (2017) + ...

(EXO)CLIMATE SIMULATIONS

Met Office Unified Model

Radiative Transfer



Accurate radiative transfer is crucial for atmospheric heating rates and thermal evolution

Temperature Forcing (Newtonian Cooling)

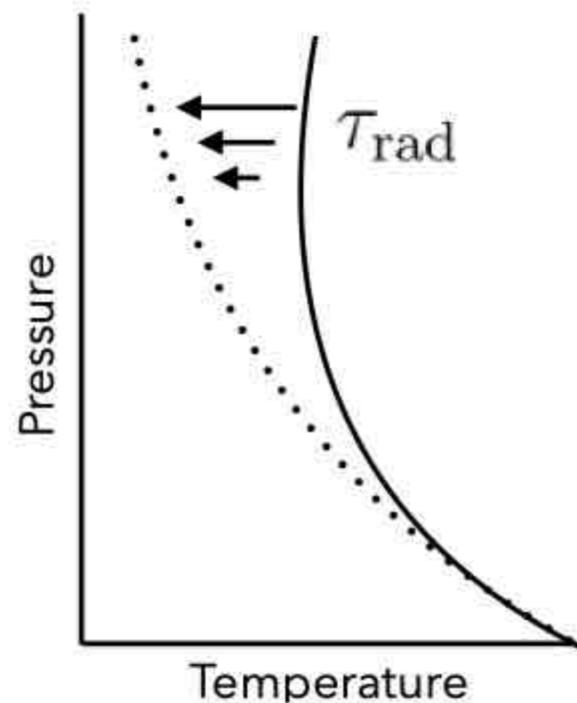

e.g. Showman & Guillot (2002), Cooper & Showman (2005), Menou & Rauscher (2009), Heng et al. (2011), Mayne et al. (2014), Mendonça et al. (2016)

Double-grey

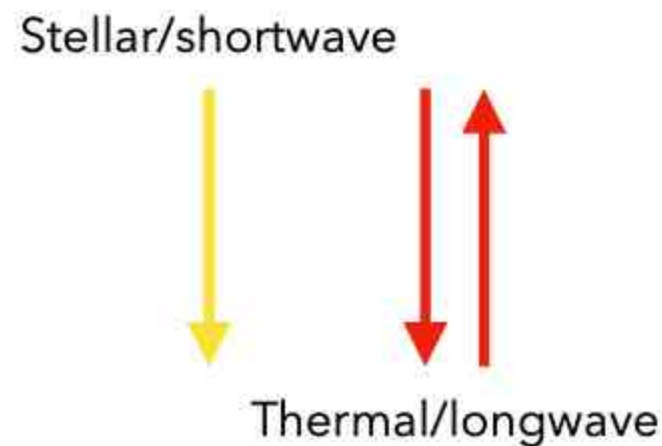

e.g. Rauscher & Menou (2012), Mendonça et al (2018)

Non-grey

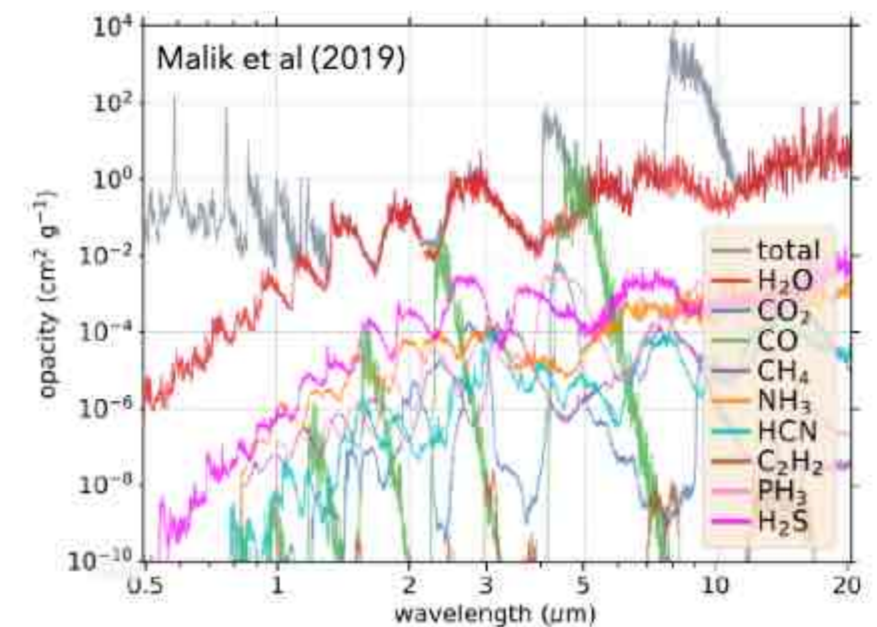

e.g. Showman et al. (2009), Dobbs-Dixon & Agol (2013), Amundsen et al. (2016)

OPACITIES

Wavenumber [cm^{-1}]

Wavenumber [cm^{-1}]

Wavenumber [cm^{-1}]

WE NEED CHEMISTRY!

WE NEED CHEMISTRY!

ExoMol

H ₂	PH ₃	AlCl	AlH	CS	HNO ₃	PN	H ₂ S	CrH	ScH	2022
LiH	OH	SO ₂	CH ₃ Cl	C ₂	BeH	PS	KCl	HCN	HNC	
HeH ⁺	NO	LiH ⁺	HCl	CH ₄	NaCl	SiO	MgH	CH	CN	
H ₃ ⁺	O ₃	H ₂ CO	HDO	H ₂ O	NH ₃	CaH	SO ₃	CO	CO ₂	
H ₂ D ⁺	O ₂	HOOF	CH ₃ F	TiO	VO	FeH	CaO	C ₃	C ₂ H ₂	To-Do
NS	NaH	OH ₃ ⁺	CH ₃	CH ₃ D	YO	SiH ₄	PH	SH	C ₂ H ₄	
VN	P ₂ H ₂	SO	SiH	SiS	NiH	TiH	MgO	CH ₃ Cl	C ₂ H ₆	
CaF	KF	PO	LiCl	LiF	MgF	SiC	NaF	PS	C ₃ H ₈	
NaO	OH ₃ ⁺	ZnS	SiO ₂	KOH	NaOH	CaOH	PO ₂	N ₂	SiH ₂	

Wavelength [μm]

Wavelength [μm]

(EXO)CLIMATE SIMULATIONS

Met Office Unified Model

Chemistry



Chemical equilibrium

Composition is a function of *local* T and P

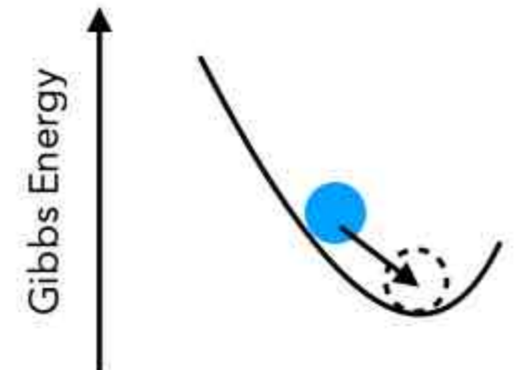

$$G = \sum_i \mu_i N_i \quad \mu_i(T, P) = \mu_i^0(T) + RT \ln P + RT \ln \left(\frac{N_i}{N_{tot}} \right)$$

(EXO)CLIMATE SIMULATIONS

Met Office Unified Model

Chemistry



Chemical equilibrium

Composition is a function of *local* T and P

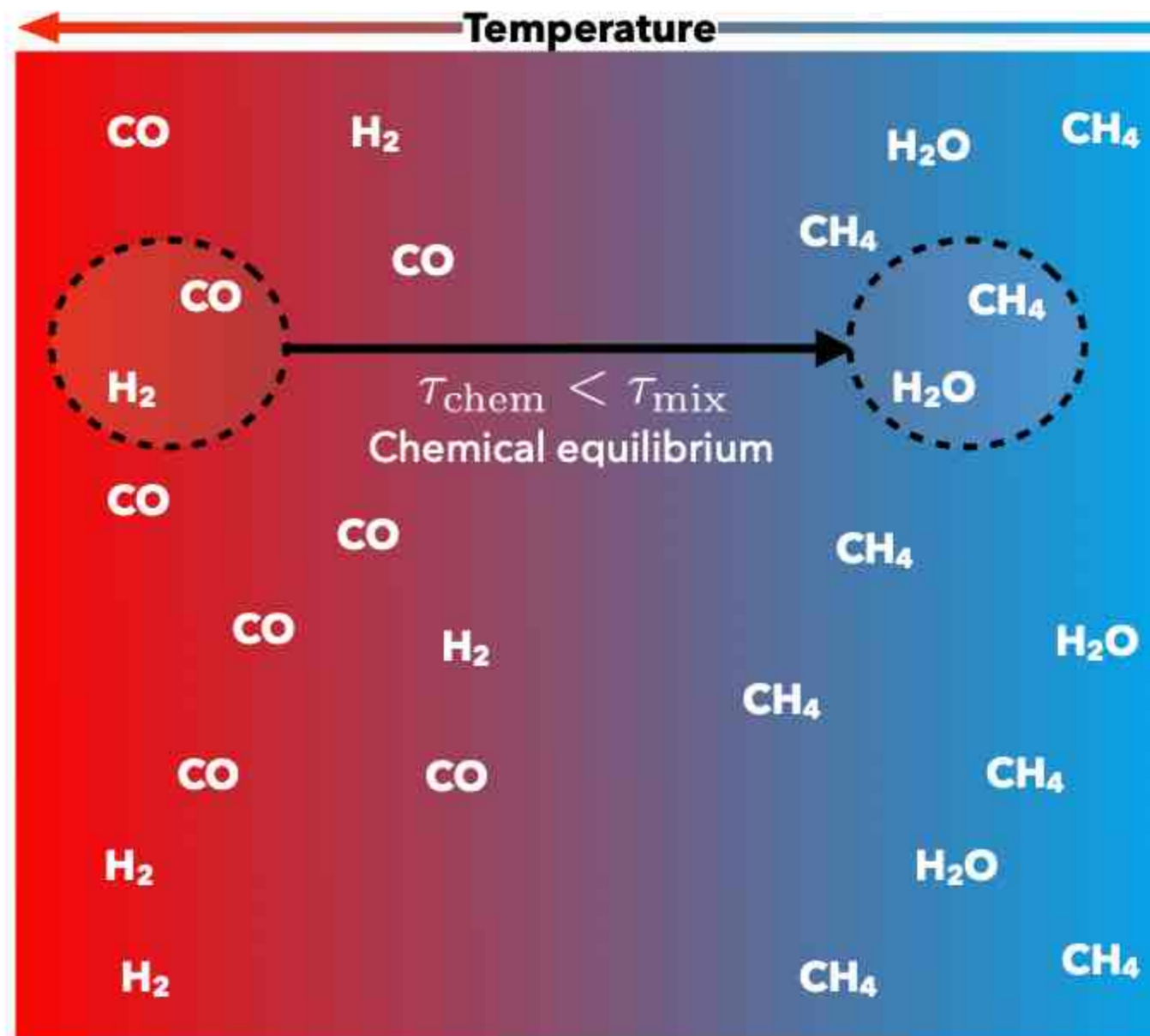

(EXO)CLIMATE SIMULATIONS

Met Office Unified Model

Chemistry



Drummond et al., A&A (2018)

Ben Drummond



Chemical equilibrium

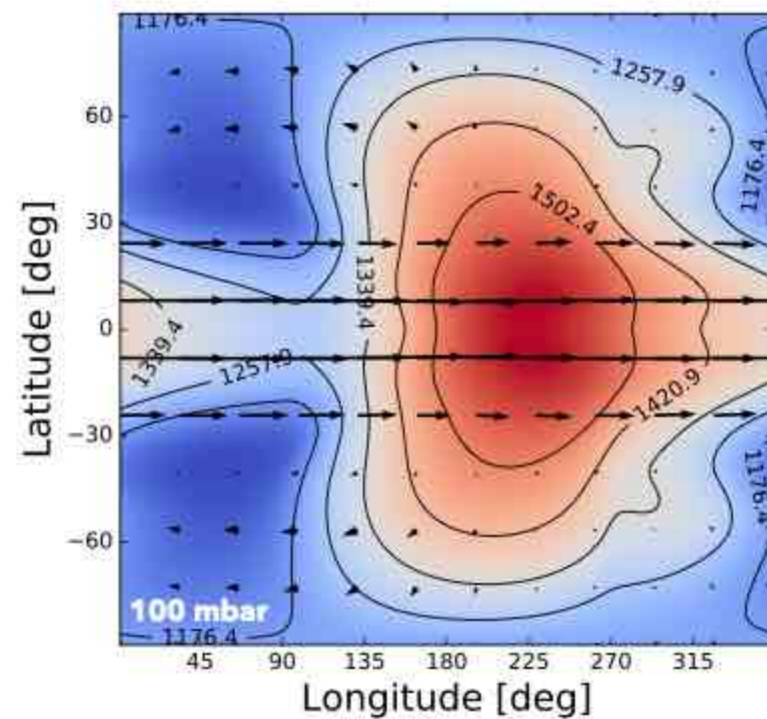

HD209458b

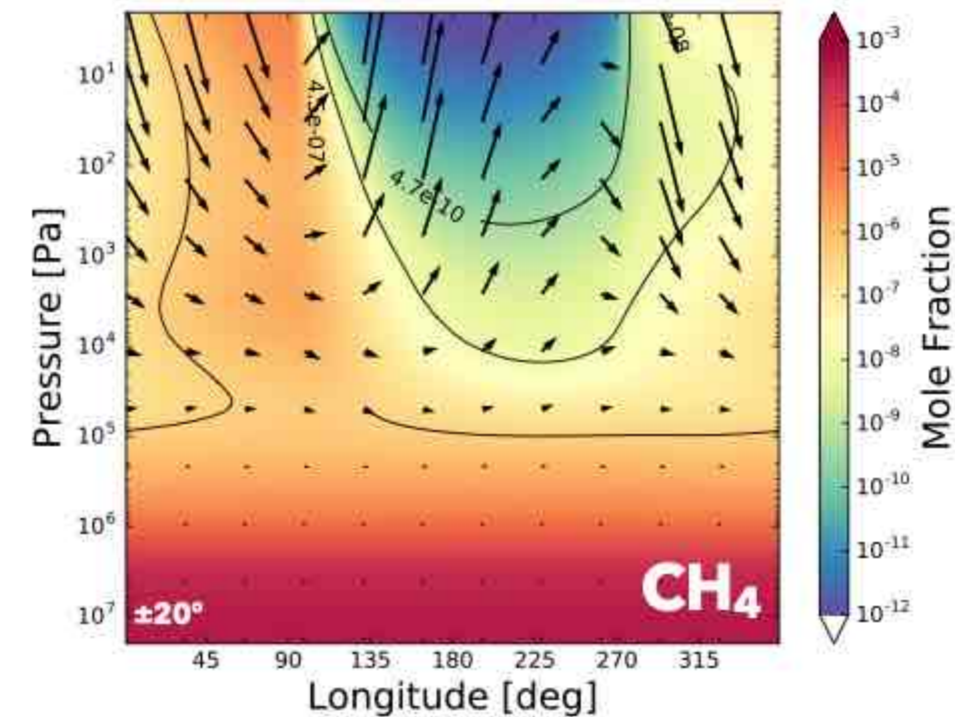
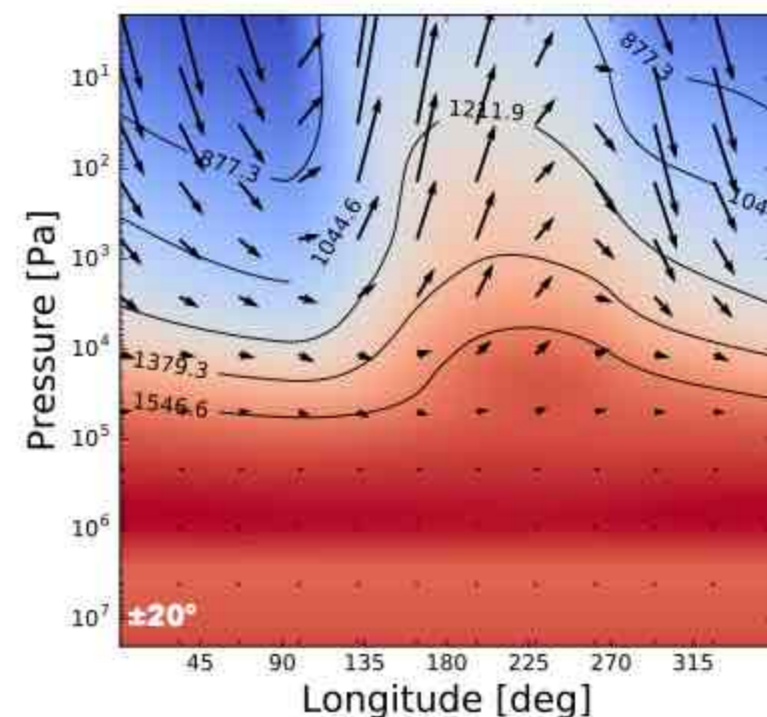
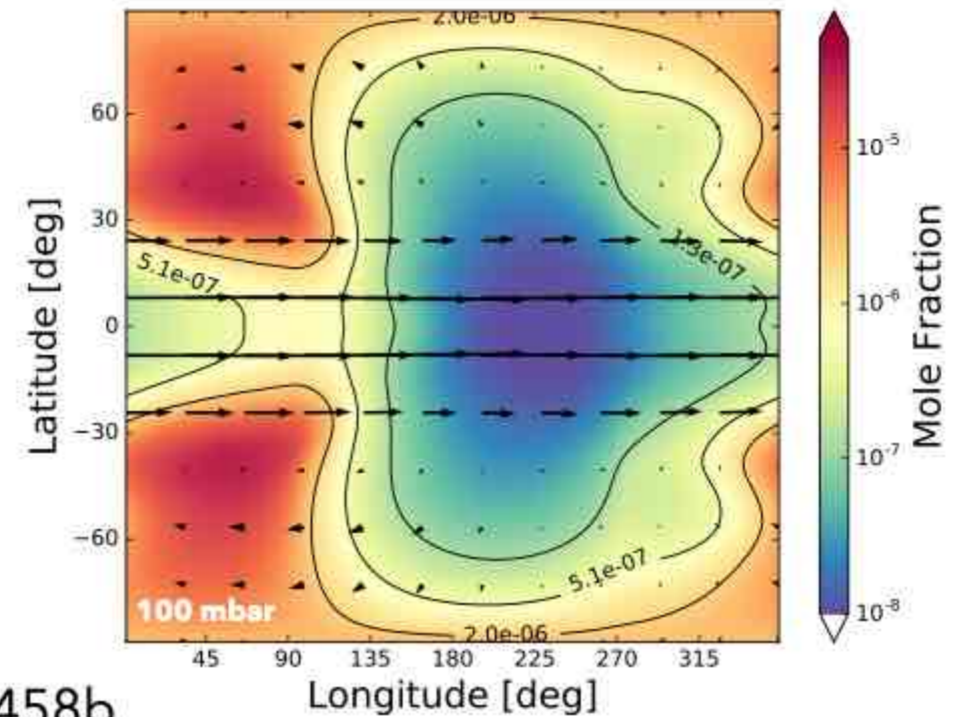

(EXO)CLIMATE SIMULATIONS

Met Office Unified Model

Chemistry



Chemical equilibrium

Composition is a function of *local* T and P

Drummond et al., A&A (2018)

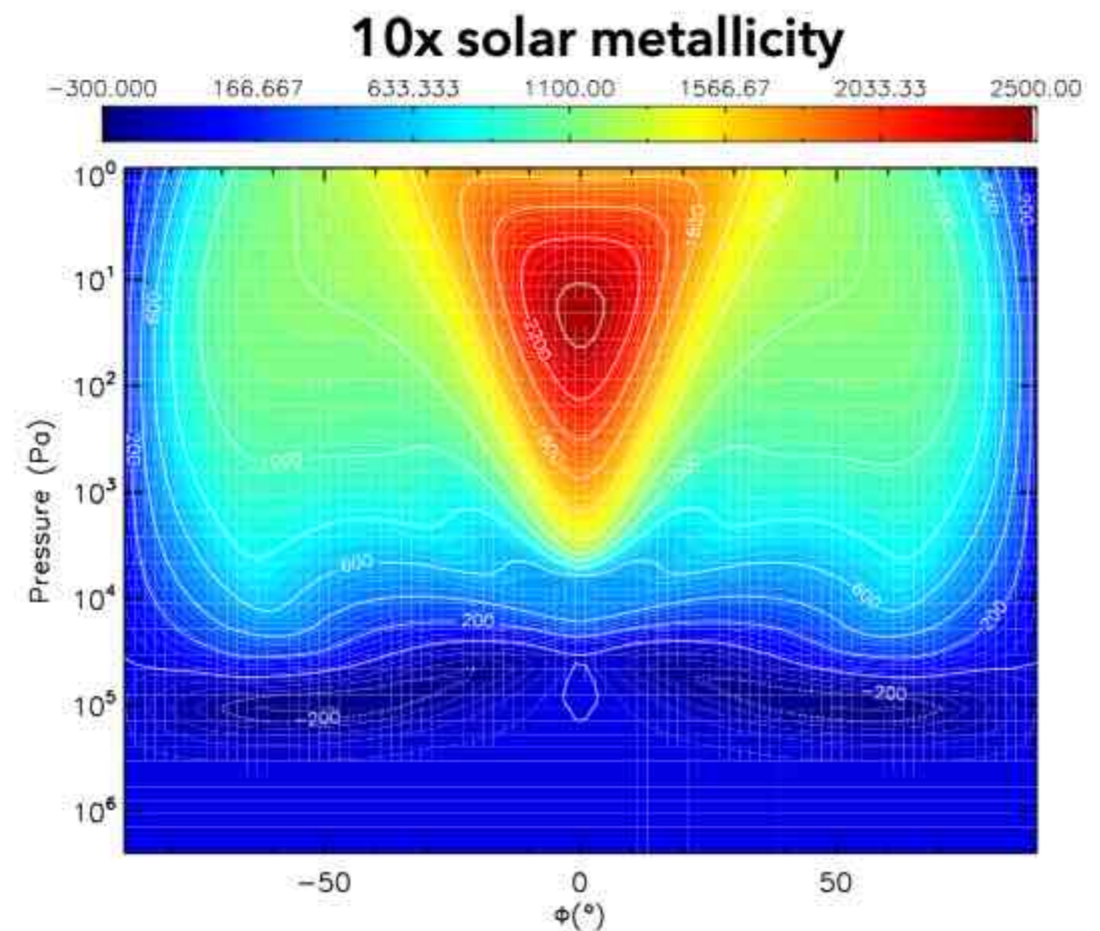
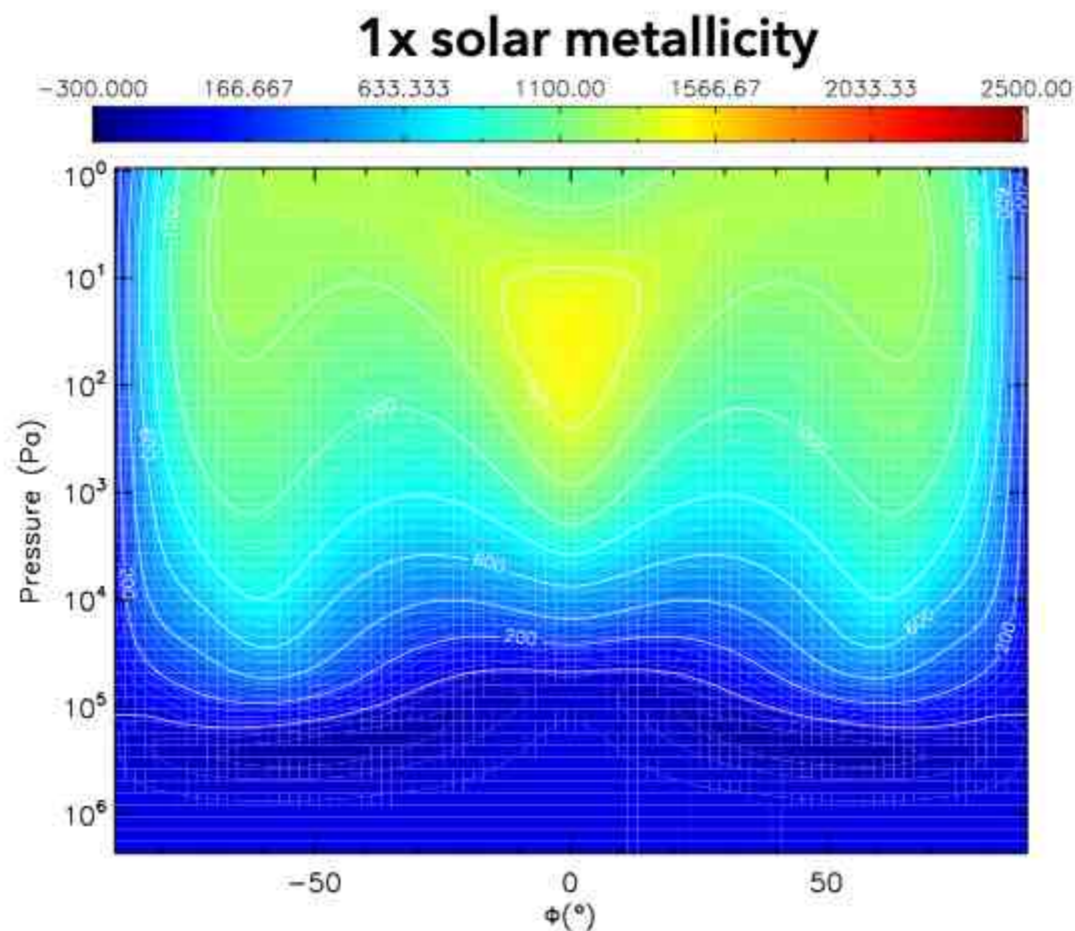

(EXO)CLIMATE SIMULATIONS

Met Office Unified Model

Chemistry



Chemical equilibrium

Composition is a function of *local* T and P

Drummond et al., A&A (2018)

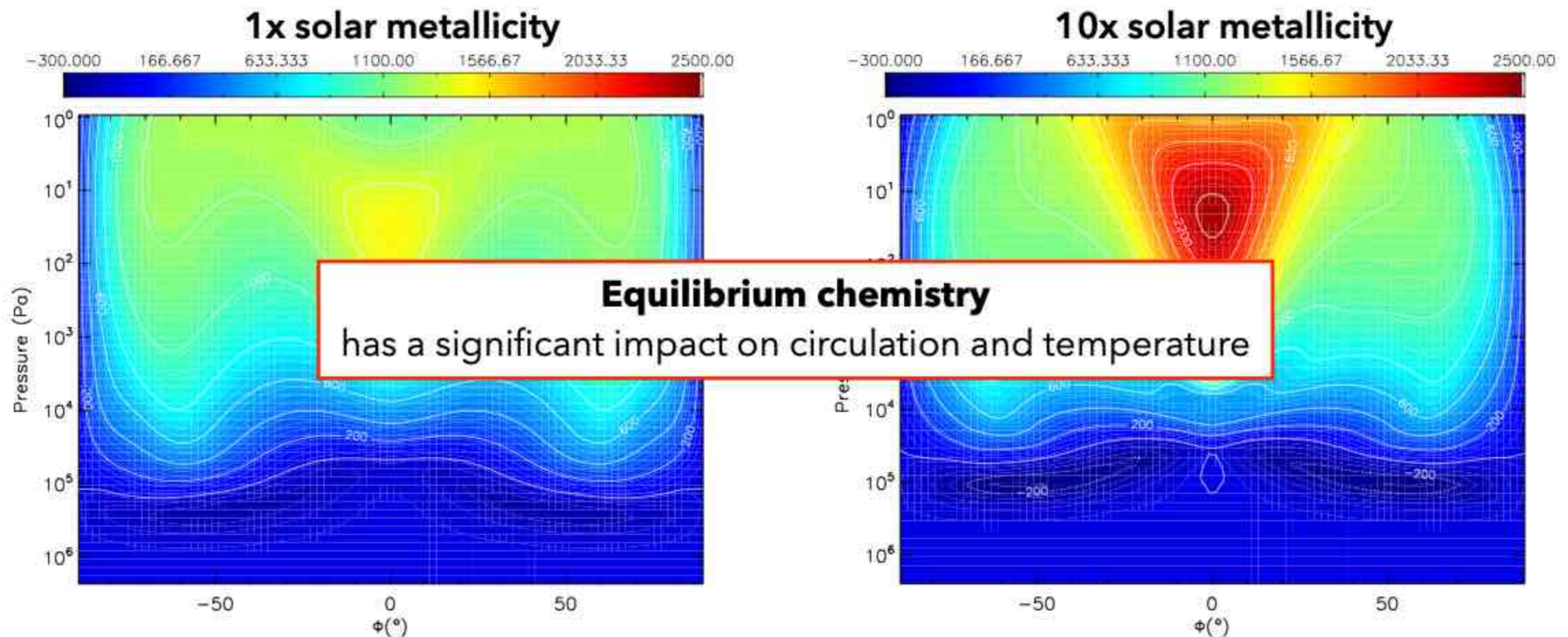

e.g. Showman et al. (2009), Amundsen et al. (2016), Kataria et al. (2014), Charnay et al. (2015), Drummond et al. (2018)

CHEMICAL **DISE**QUILIBRIUM



Chemical
Equilibrium

Temperature
Pressure
Elemental composition

CHEMICAL **DISE**EQUILIBRIUM

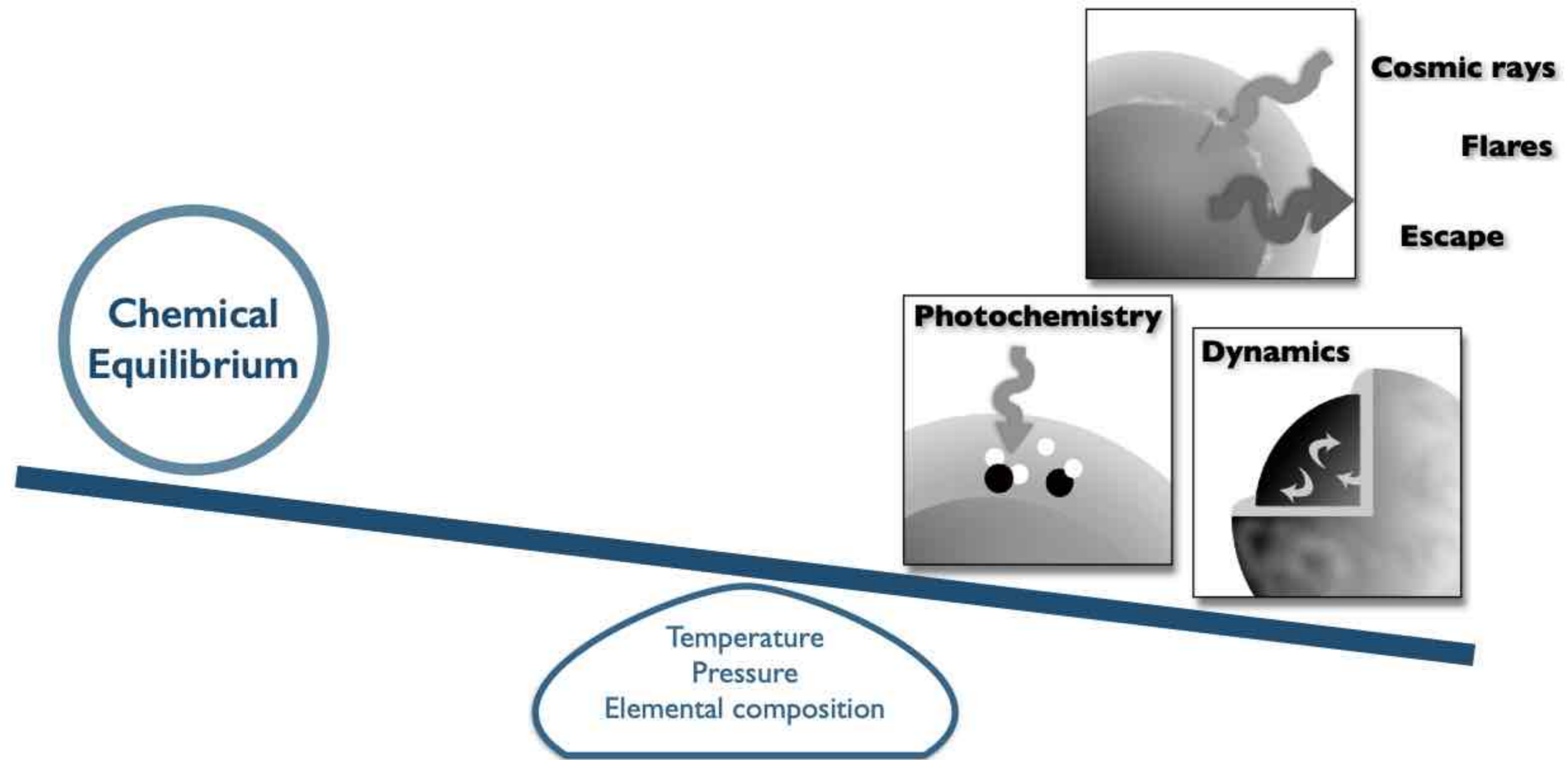

CHEMICAL DISEQUILIBRIUM

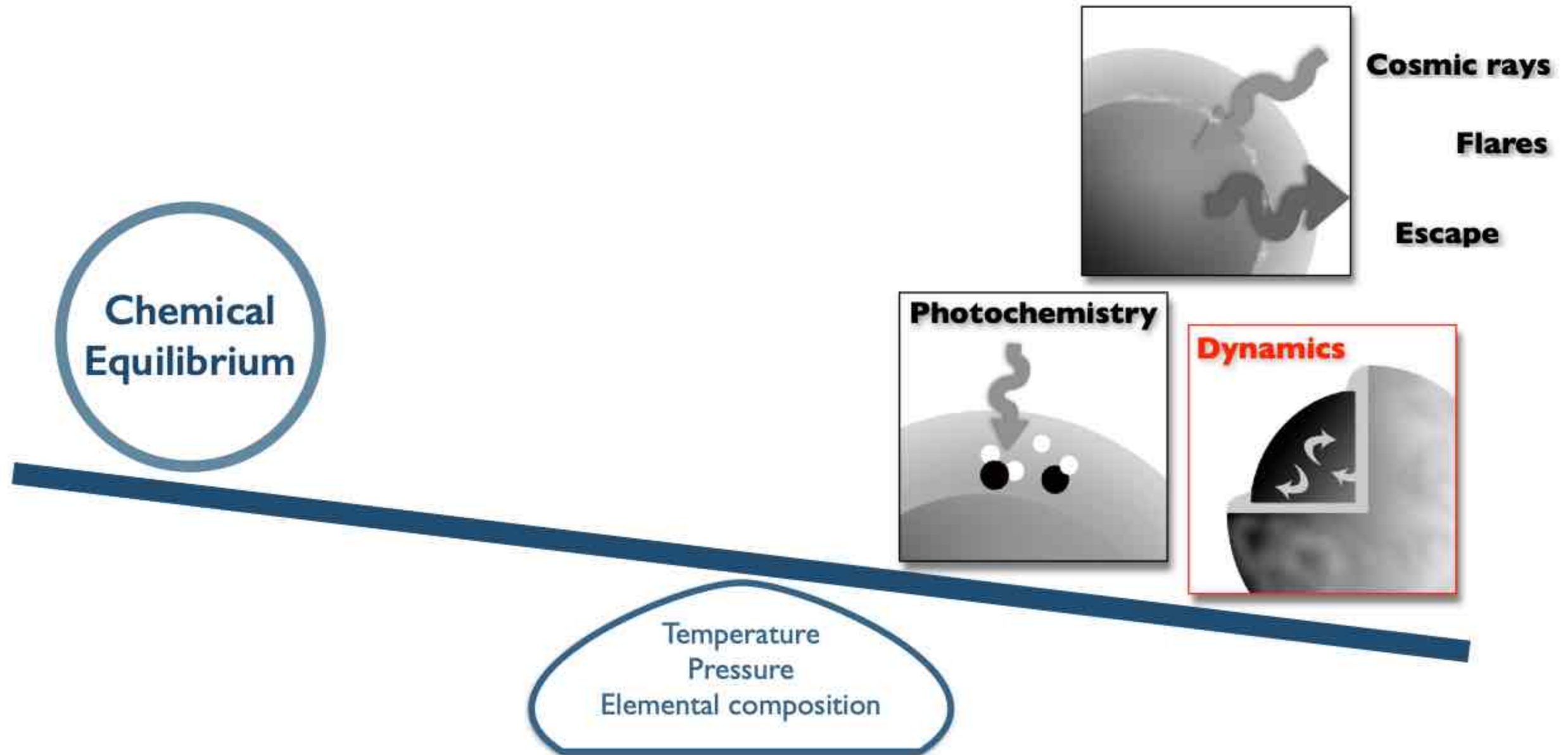

(EXO)CLIMATE SIMULATIONS

Met Office Unified Model

Chemistry



Chemical disequilibrium

Composition is **not** a function of *local* T and P

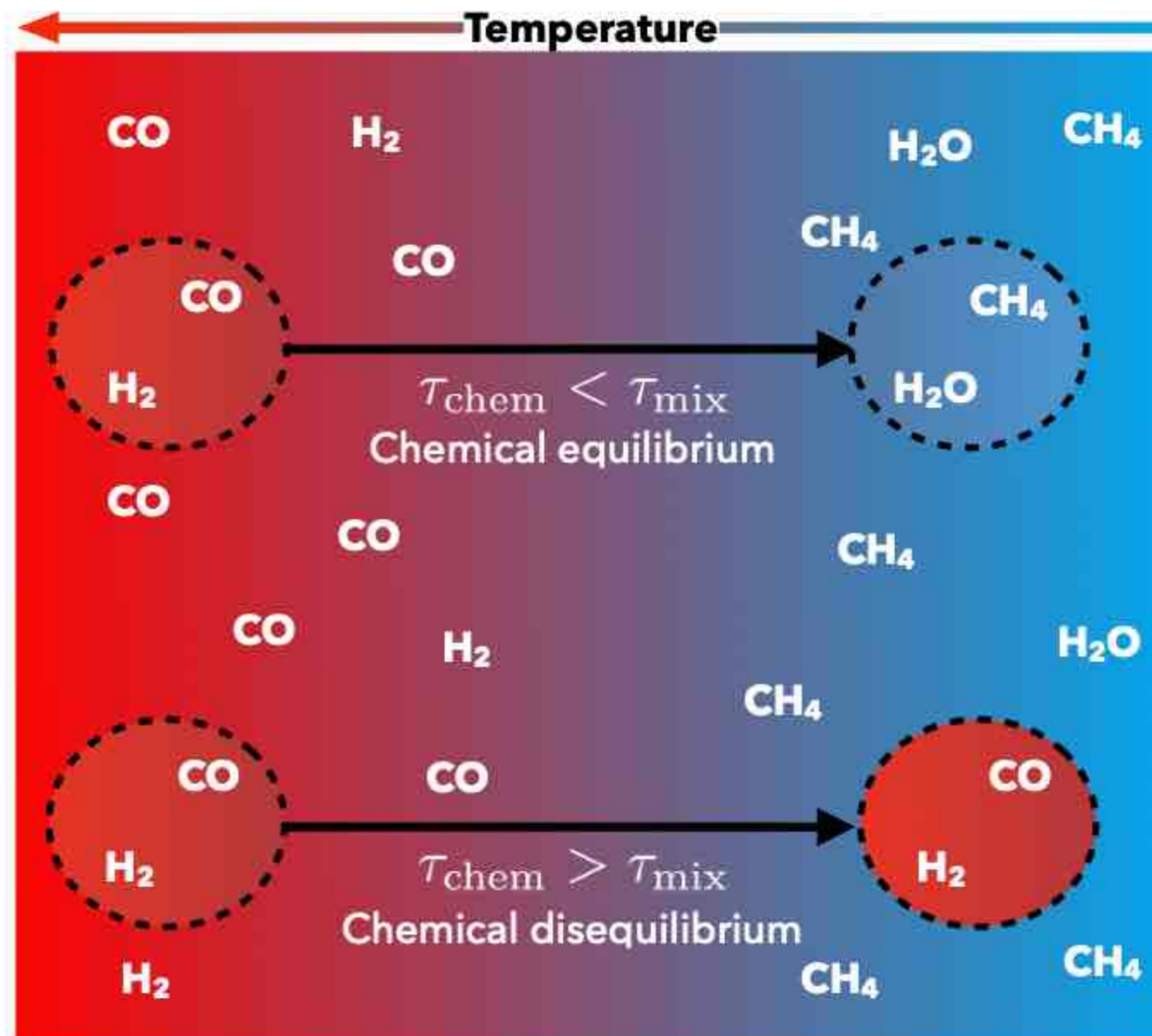

(EXO)CLIMATE SIMULATIONS

Met Office Unified Model

Chemistry

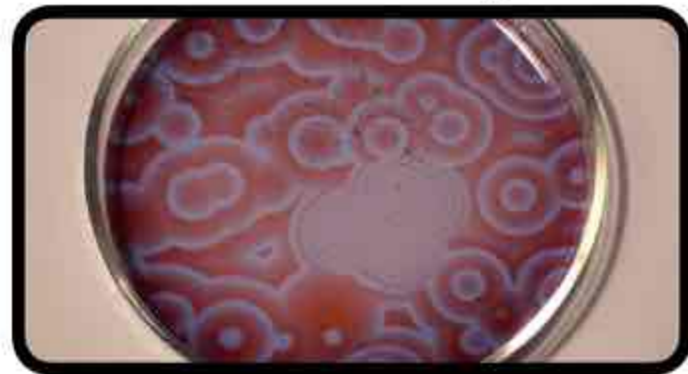

Chemical relaxation

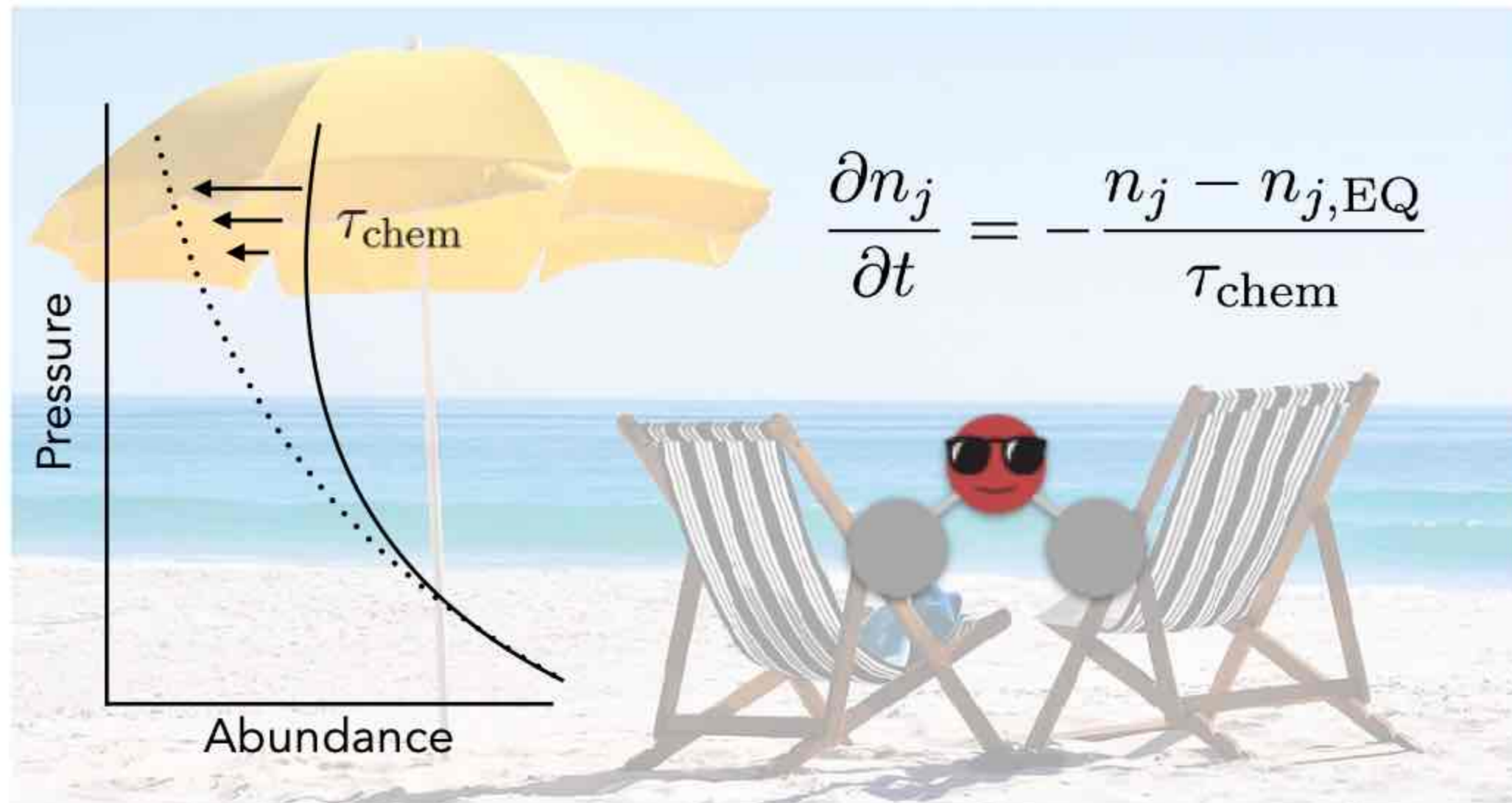

(EXO)CLIMATE SIMULATIONS

Met Office Unified Model

Chemistry



Drummond et al., A&A (2018)



Chemical equilibrium

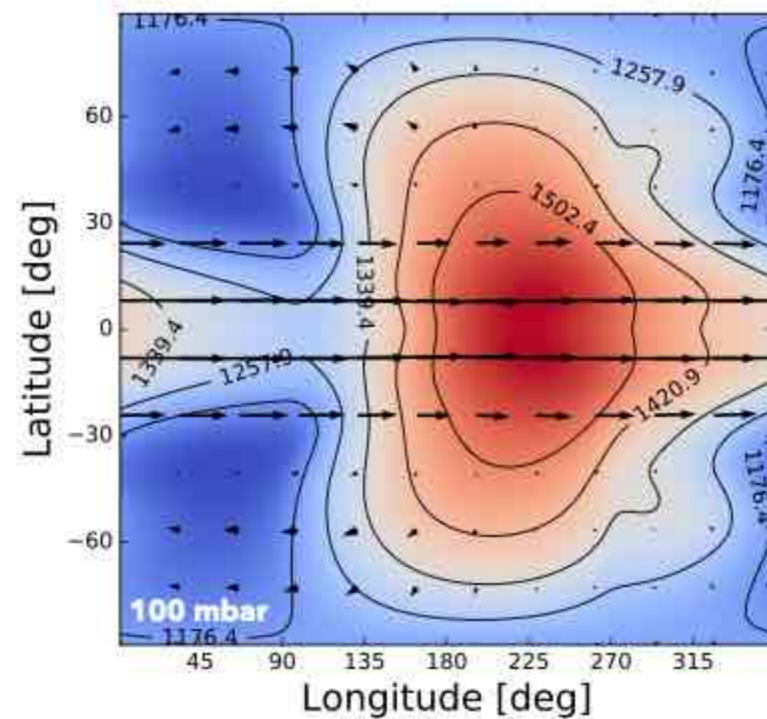

HD209458b

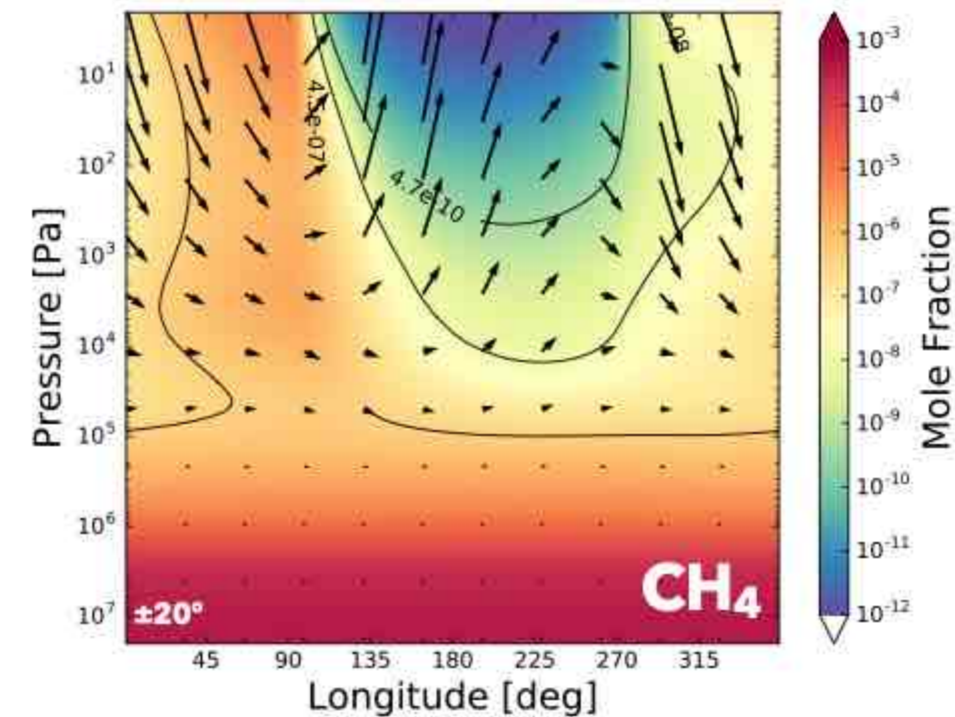
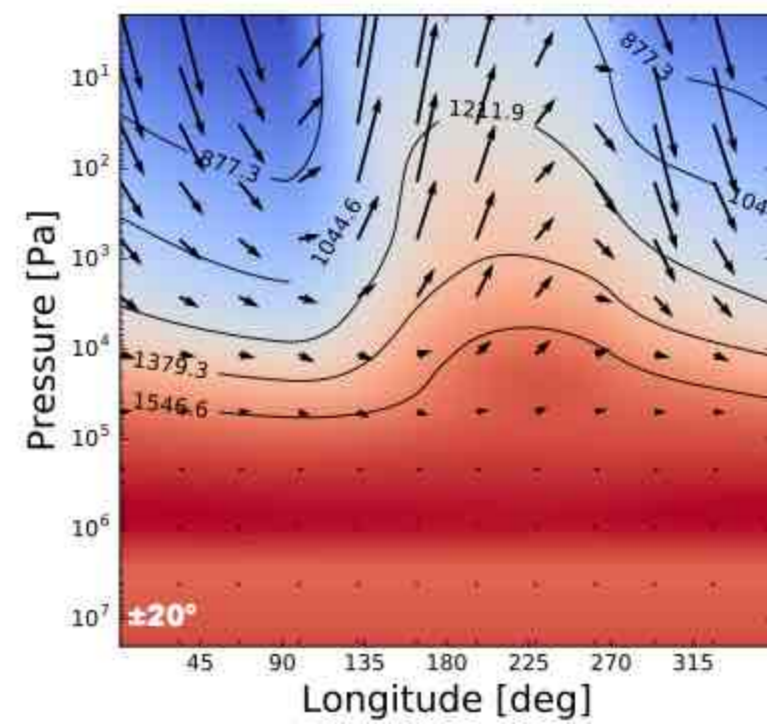
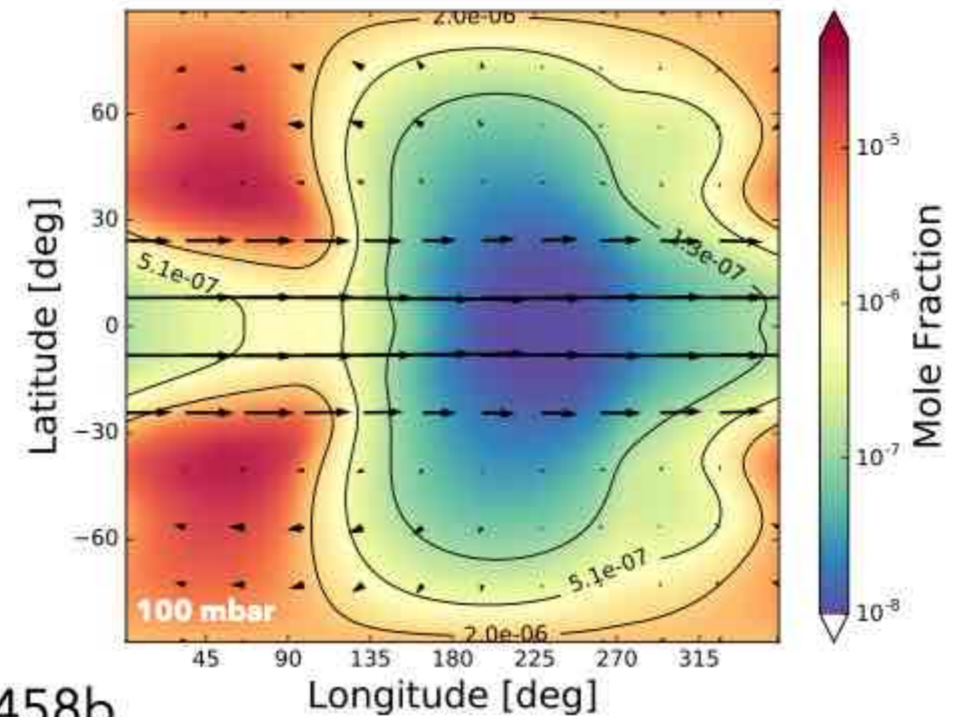

(EXO)CLIMATE SIMULATIONS

Met Office Unified Model

Chemistry



Drummond et al., ApJL (2018)



Chemical relaxation

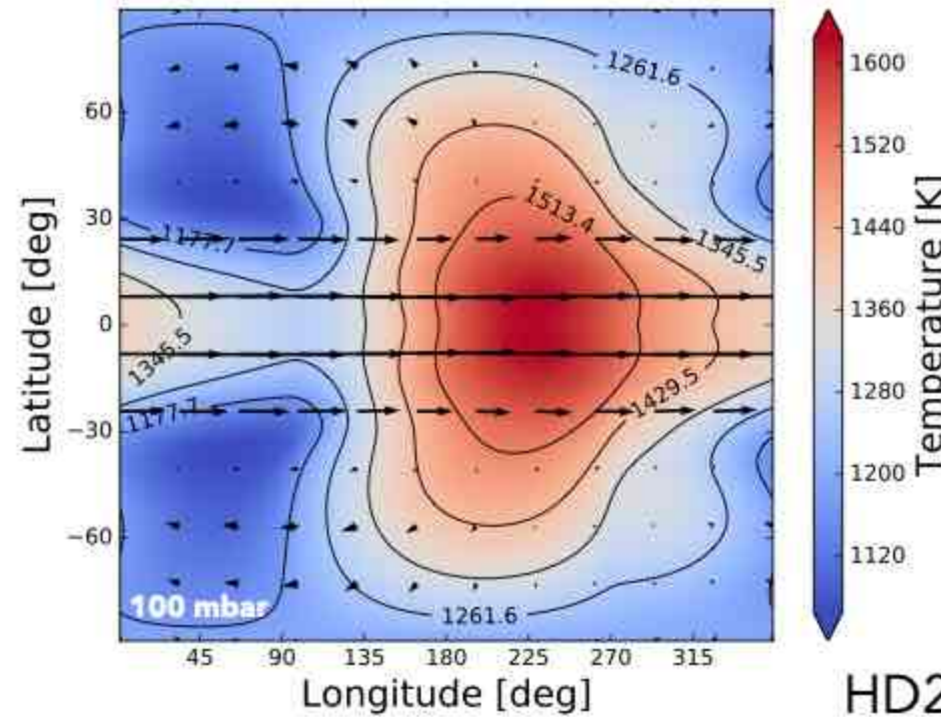

HD209458b

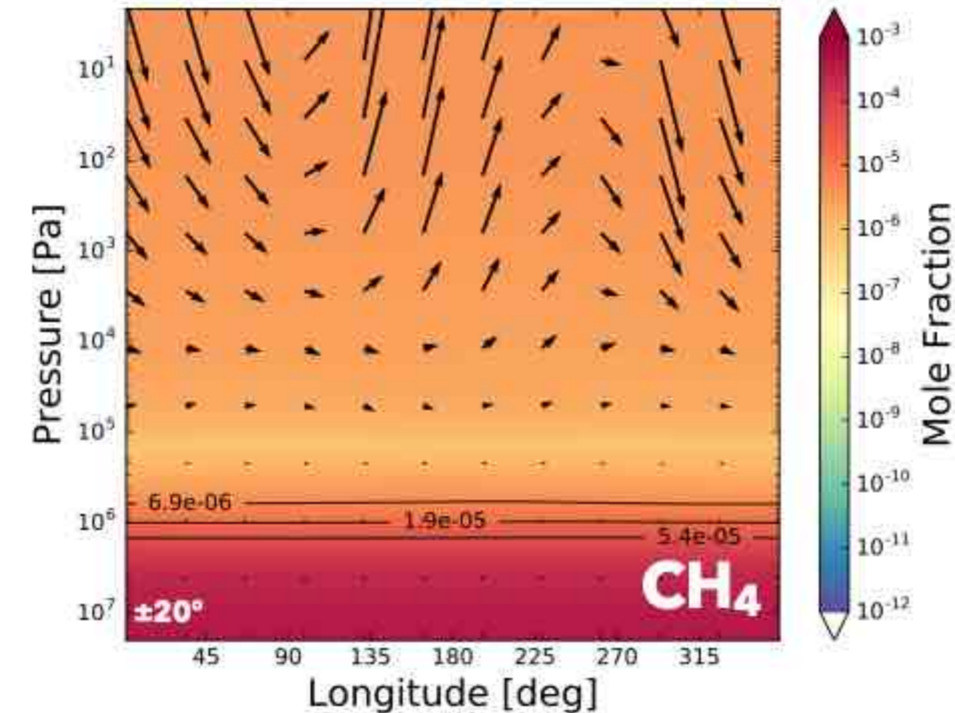
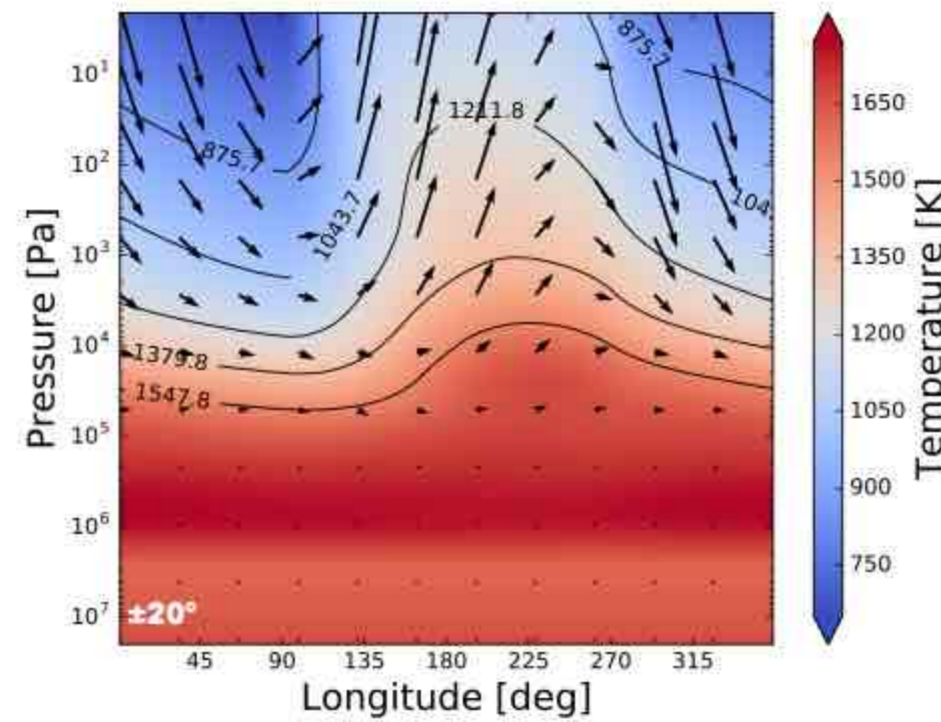
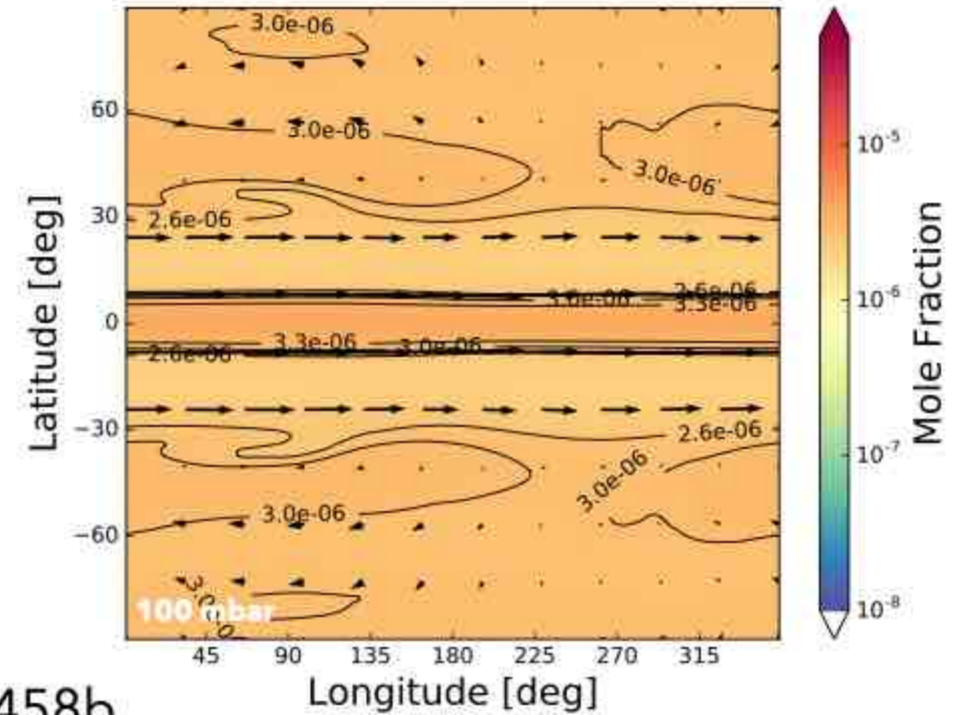

(EXO)CLIMATE SIMULATIONS

Met Office Unified Model

Chemistry



Drummond et al., ApJL (2018)

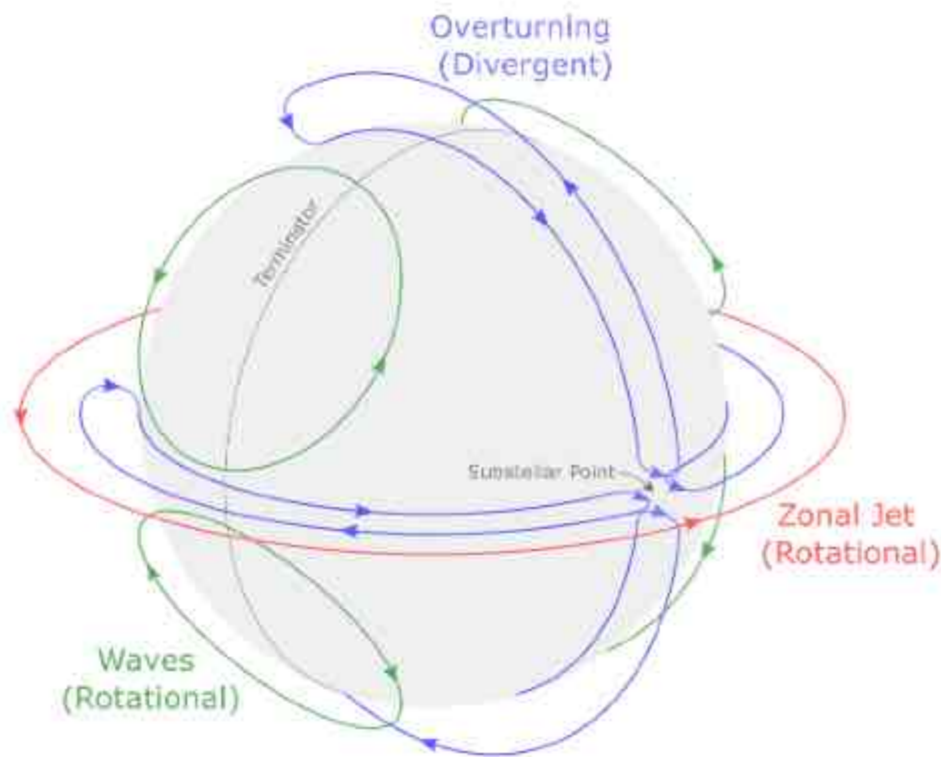

Hammond and Lewis (2021)

Chemical relaxation

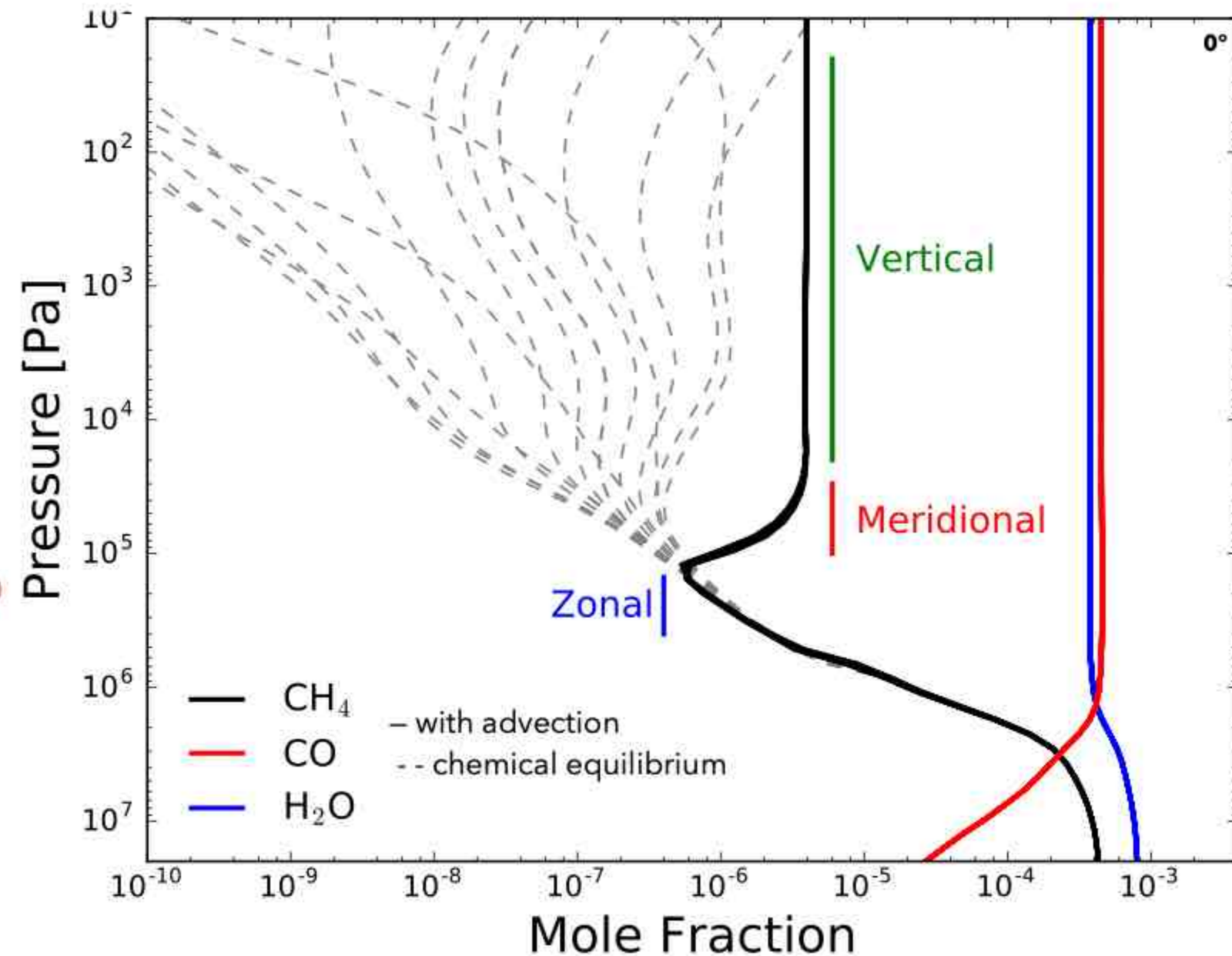

(EXO)CLIMATE SIMULATIONS

Met Office Unified Model

Chemistry

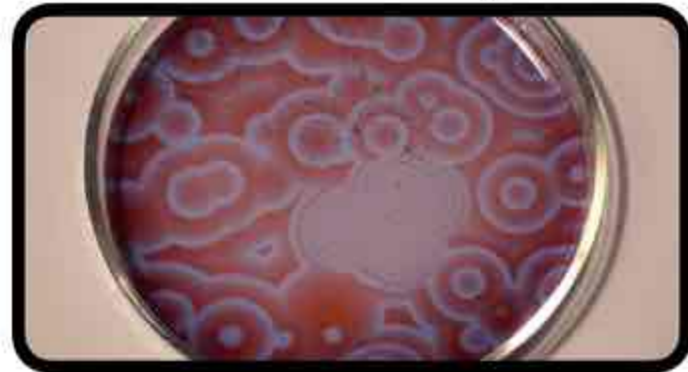

Drummond et al., ApJL (2018)

Chemical relaxation

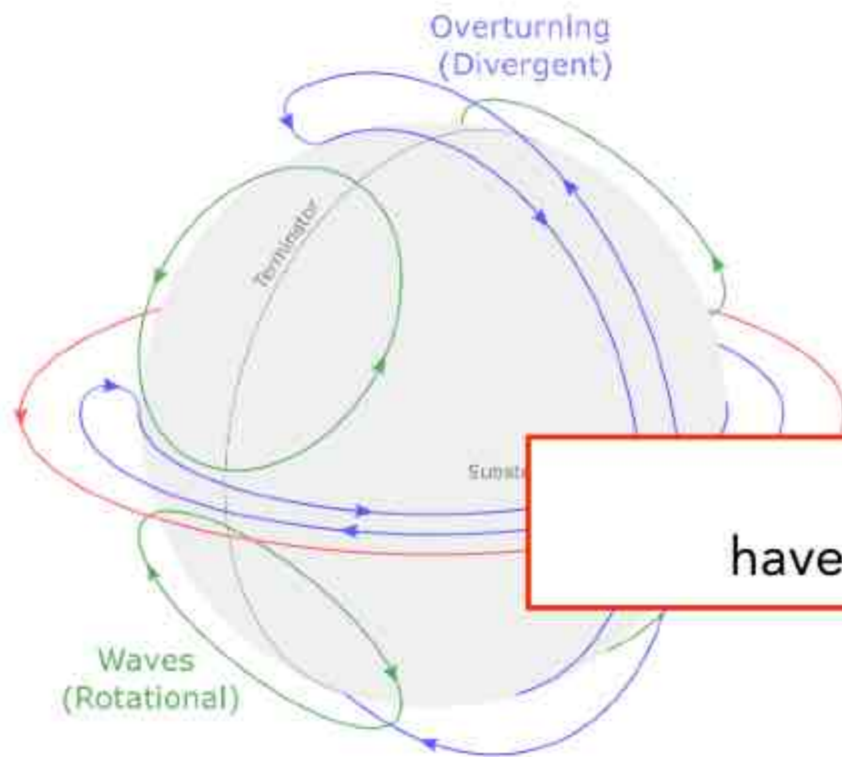
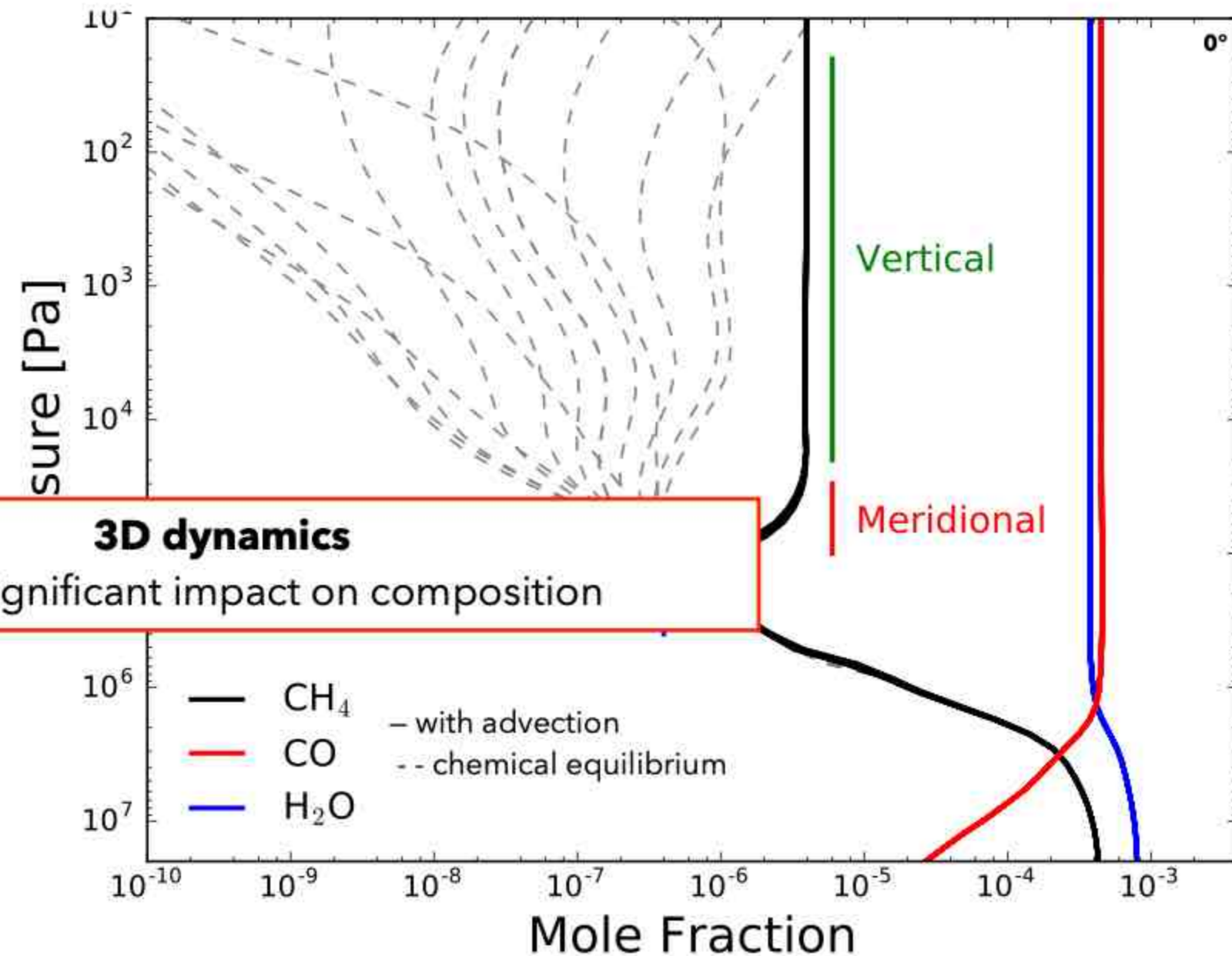

Hammond and Lewis (2021)

(EXO)CLIMATE SIMULATIONS

Met Office Unified Model

Chemistry



Chemical relaxation

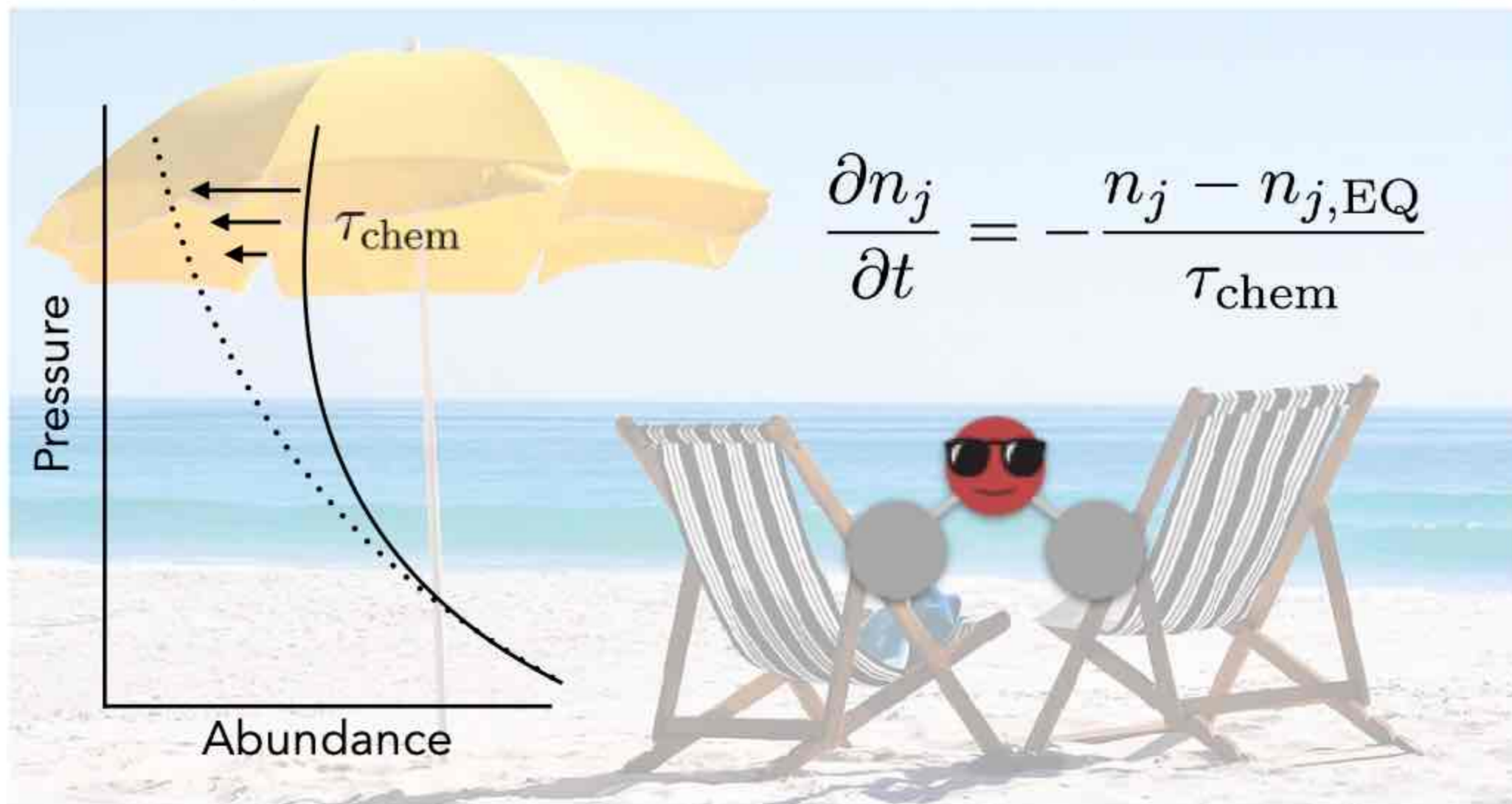

CHEMICAL DISEQUILIBRIUM

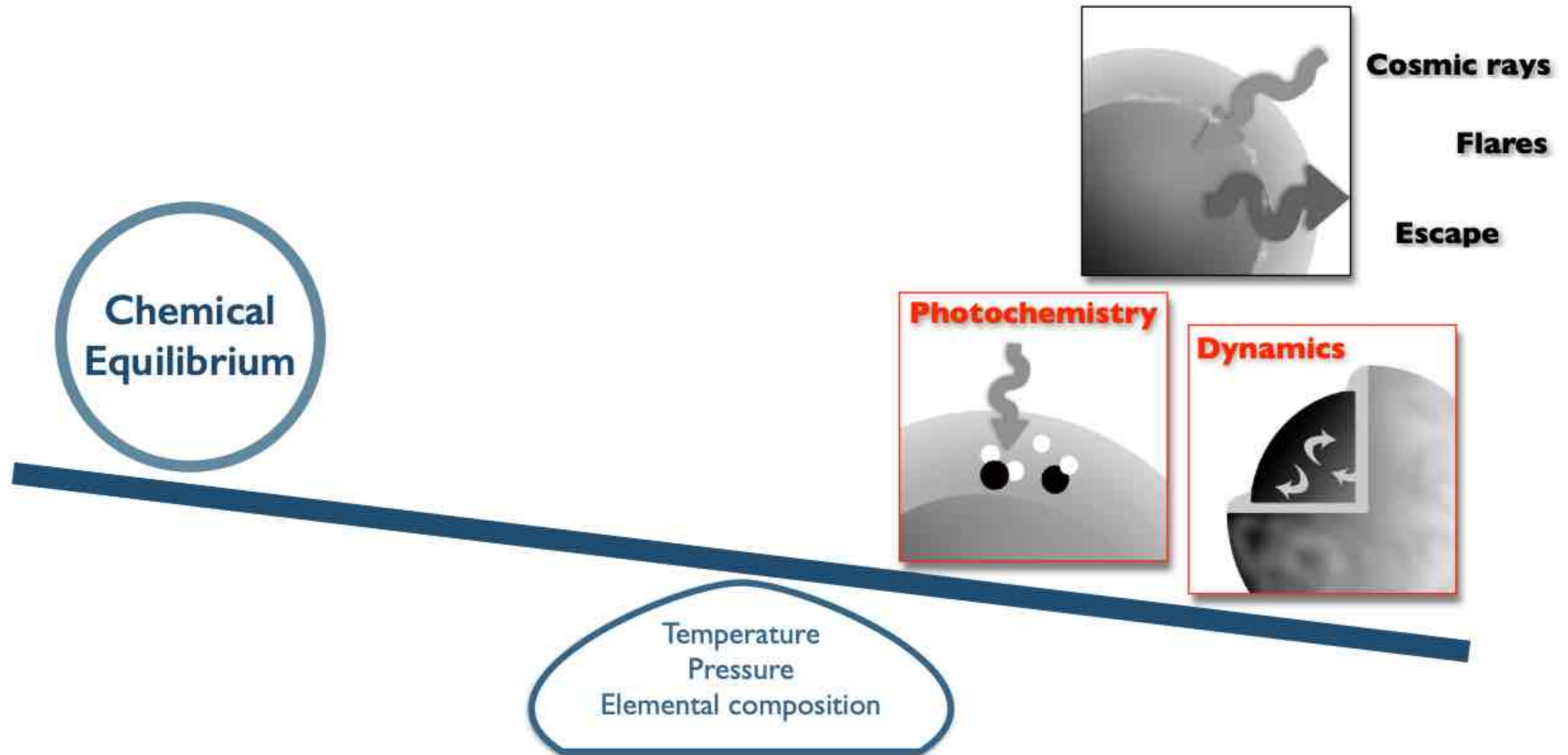

PHOTO/THERMOCHEMICAL MODELLING

Chemistry



Venot et al., A&A (2012)

Chemical kinetics

$$\frac{\partial n_j}{\partial t} = P_i - n_i L_i - \text{div} \vec{\Phi}_i$$

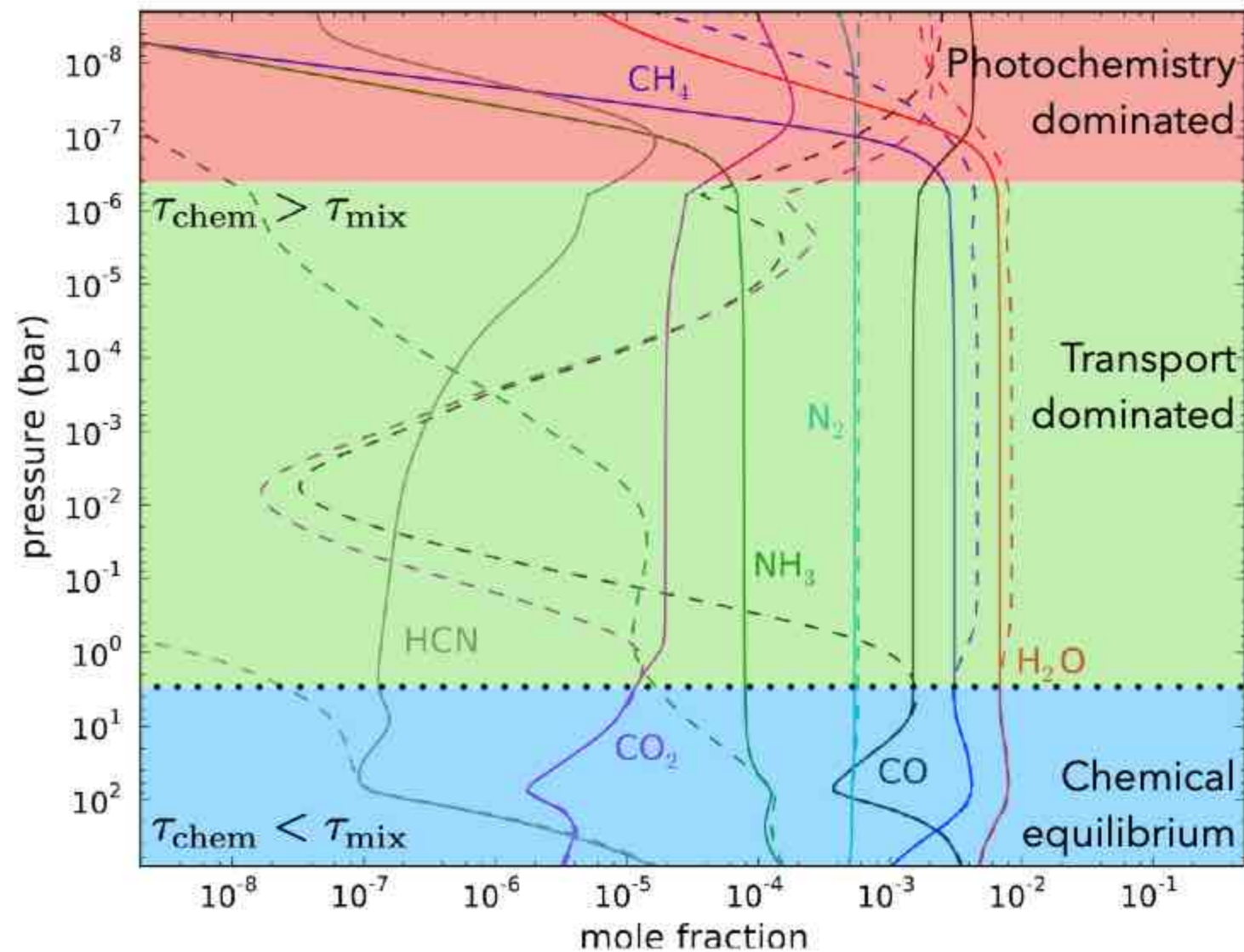

- - chemical equilibrium
- steady-state
inc. vertical mixing
and photochemistry



PHOTO/THERMOCHEMICAL MODELLING

Chemistry

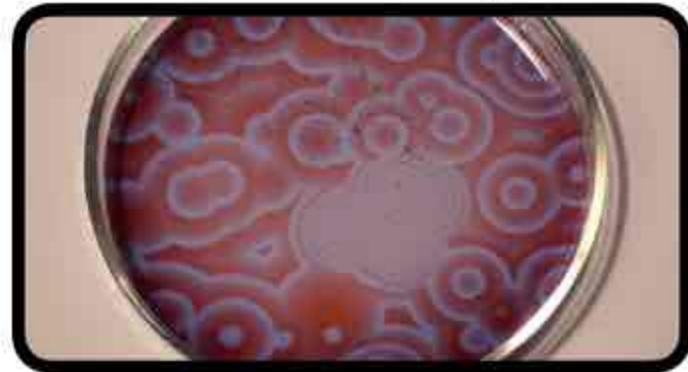

Venot et al., A&A (2012)

Chemical kinetics

$$\frac{\partial n_j}{\partial t} = P_i - n_i L_i - \text{div} \vec{\Phi}_i$$

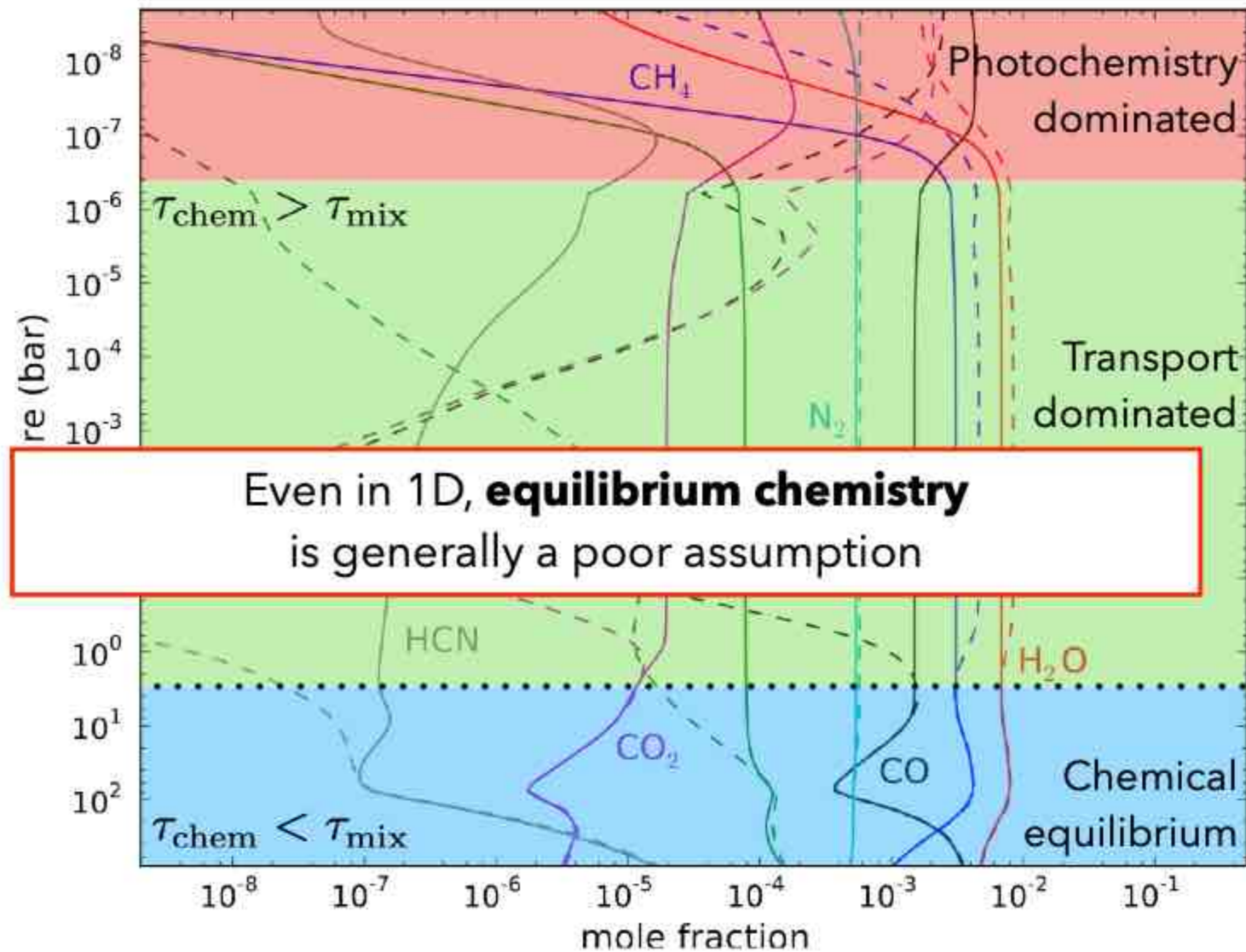

- - chemical equilibrium
- steady-state inc. vertical mixing and photochemistry



PHOTO/THERMOCHEMICAL MODELLING

Chemistry



Tsai et al., Nature (2024)

Chemical network

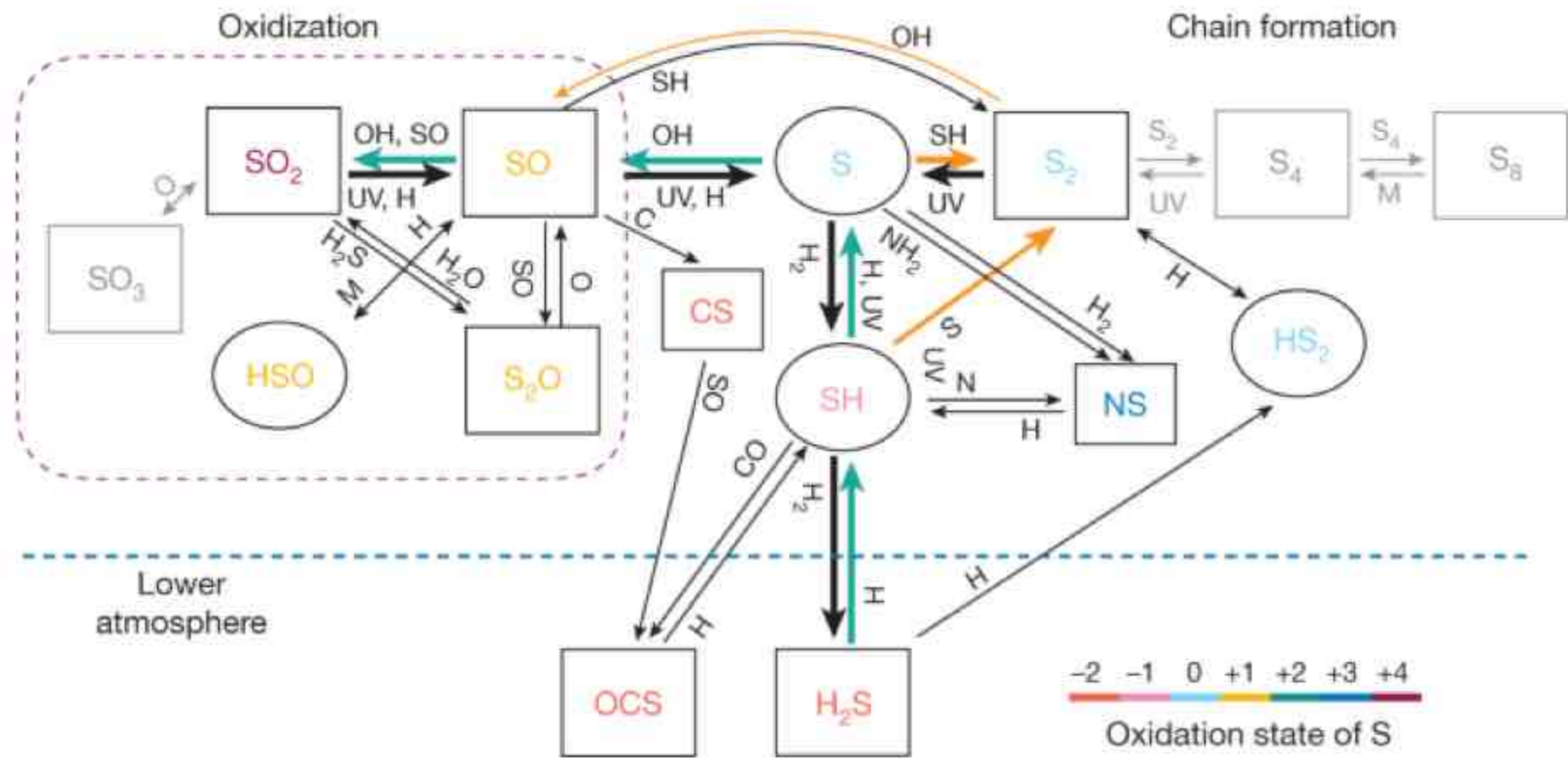

τ_{chem}

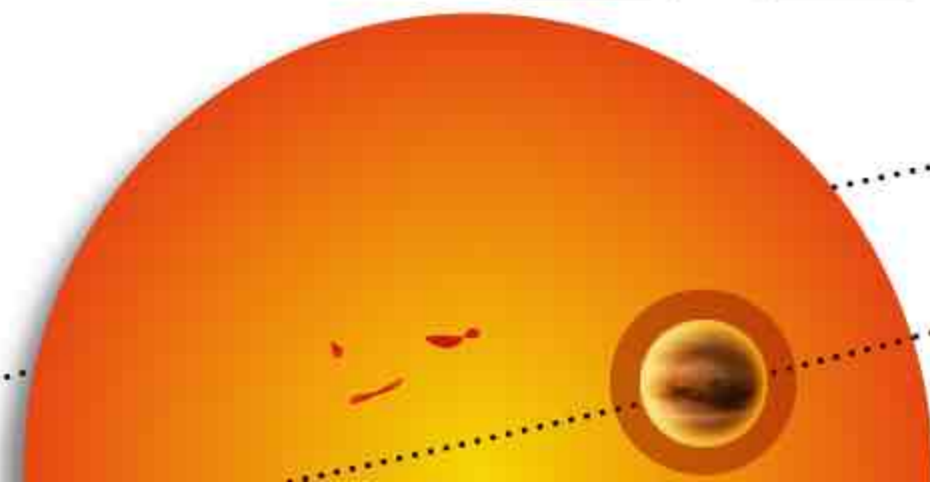

WASP-39b

PHOTO/THERMOCHEMICAL MODELLING

Chemistry



Chemical network

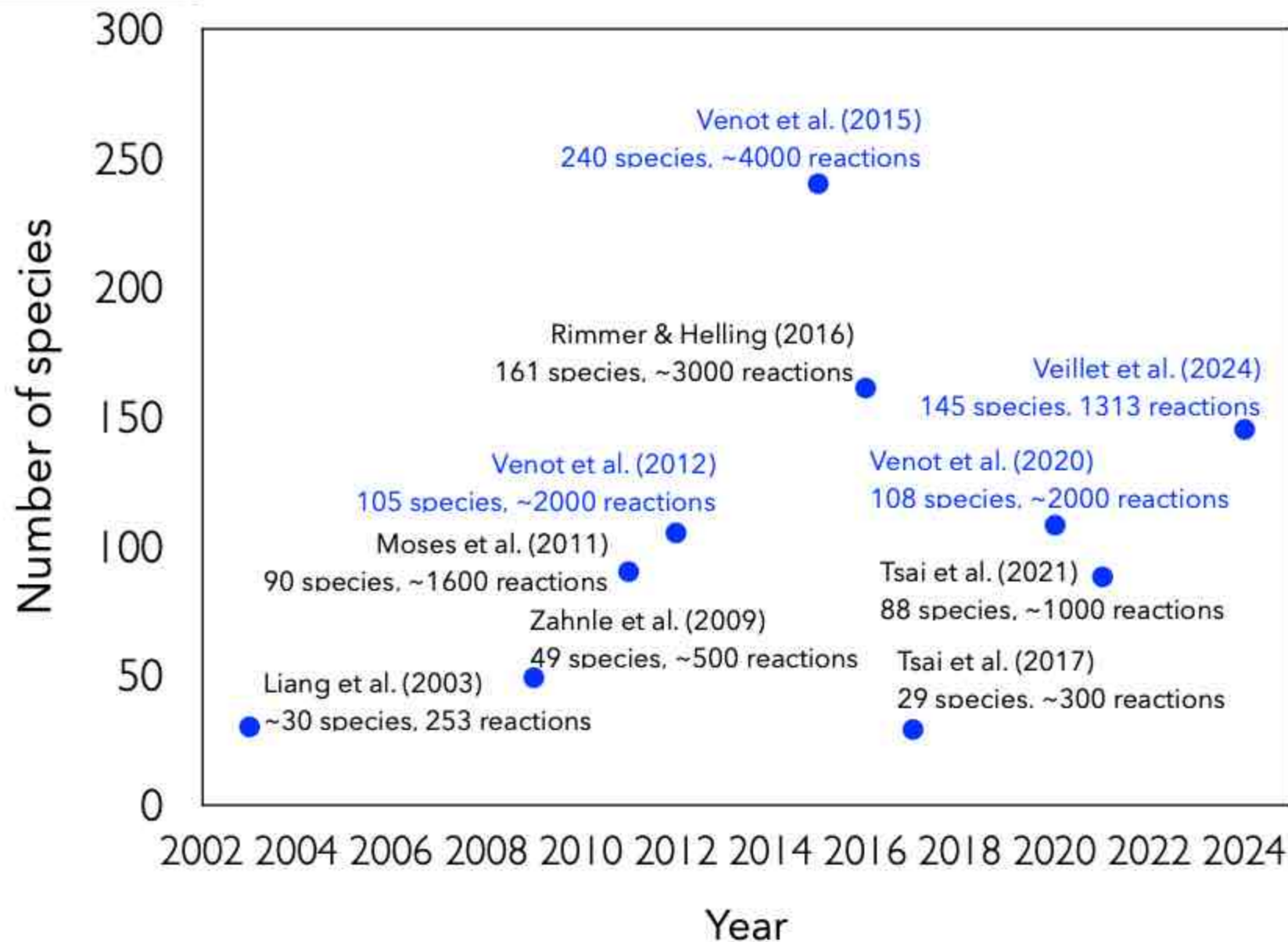

PHOTO/THERMOCHEMICAL MODELLING



+

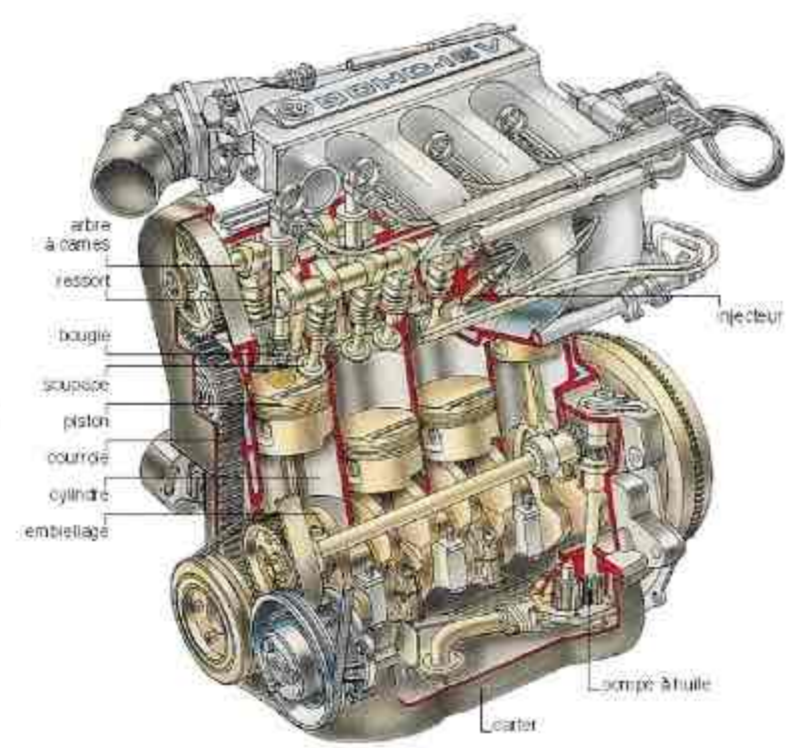

$C_0-C_2 / C_0-C_6 + NO_x$
+ PAHs + organic soots

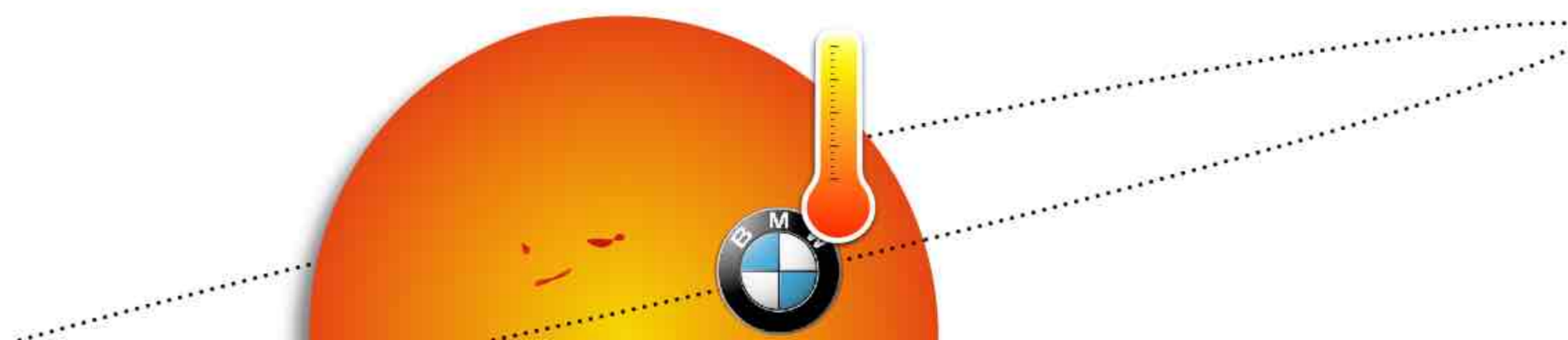

COMBUSTION MODELLING

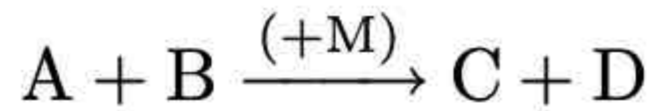

$$k_i(T) = \alpha_i \left(\frac{T}{300}\right)^{\beta_i} \exp\left(-\frac{\gamma_i}{T}\right)$$

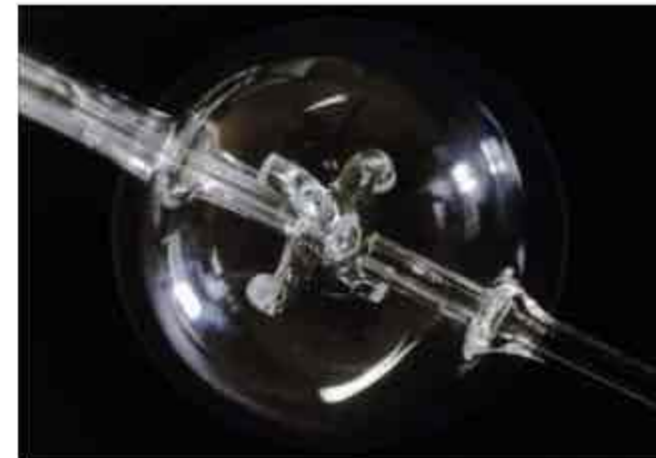

Perfectly Stirred Reactor



Shock Tube



Flame speeds



Rapid Compression Machine

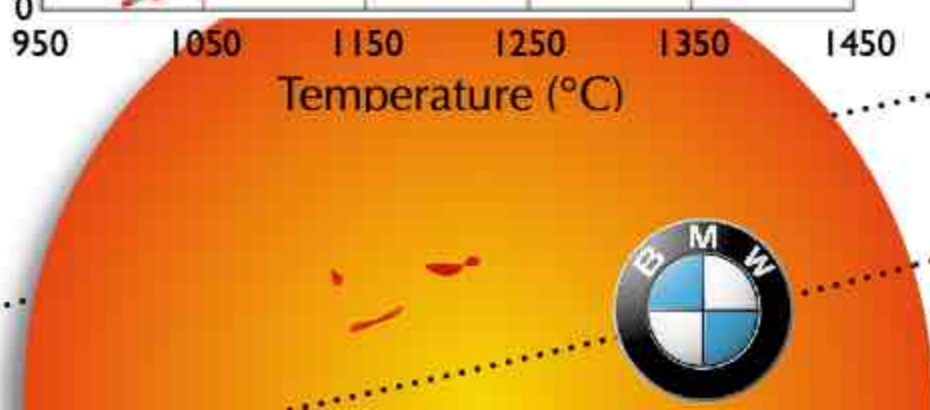
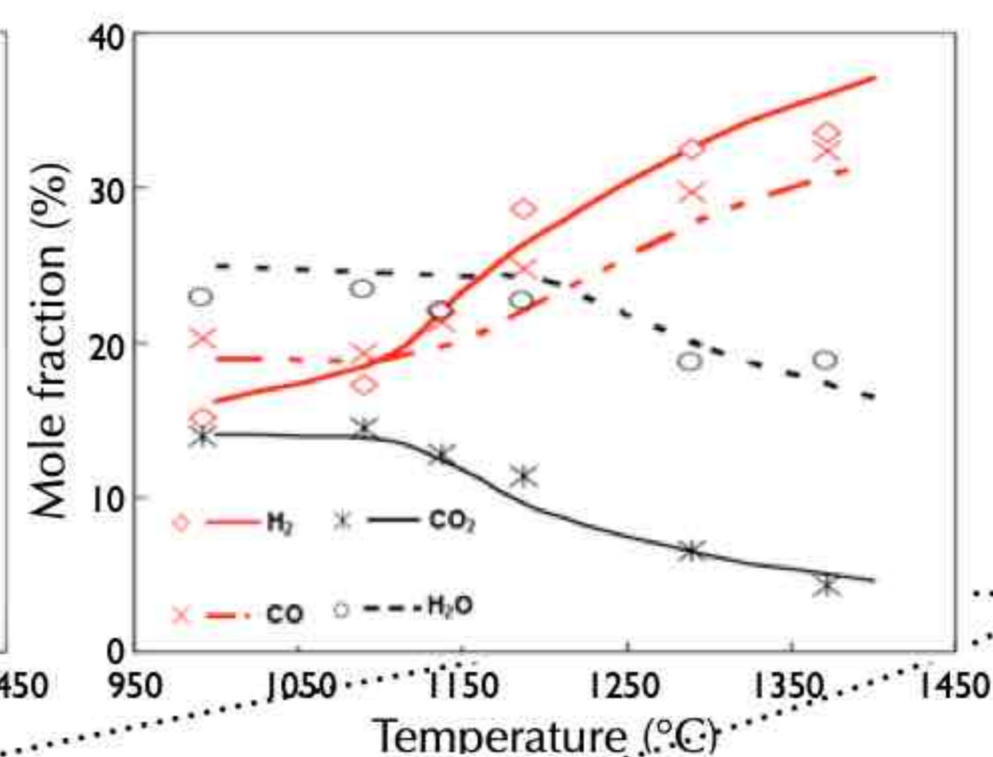
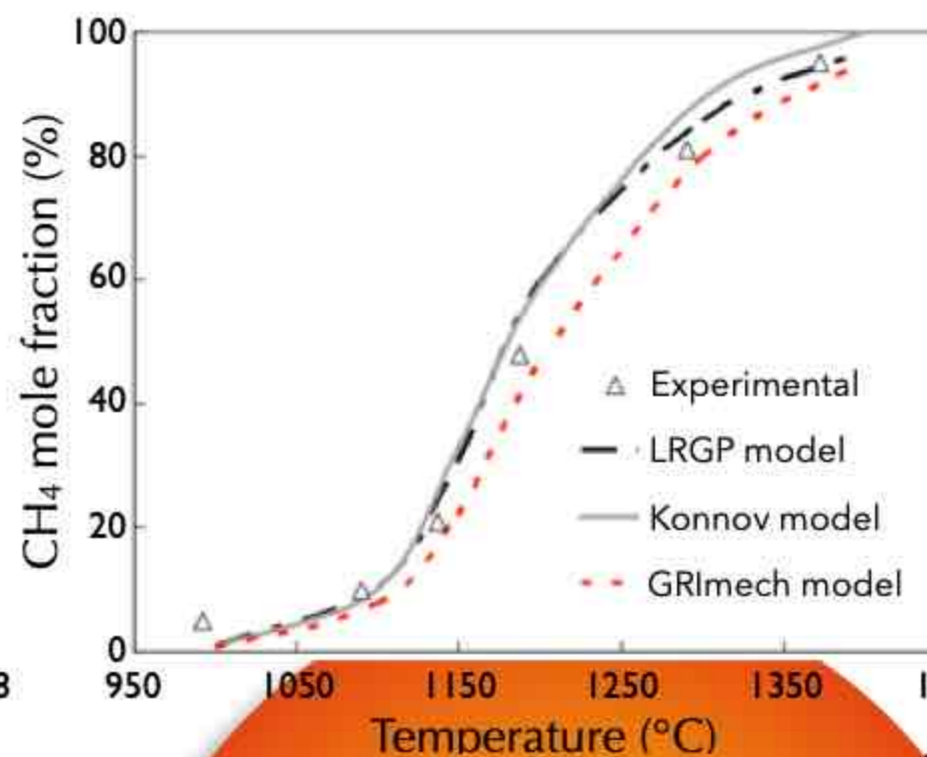
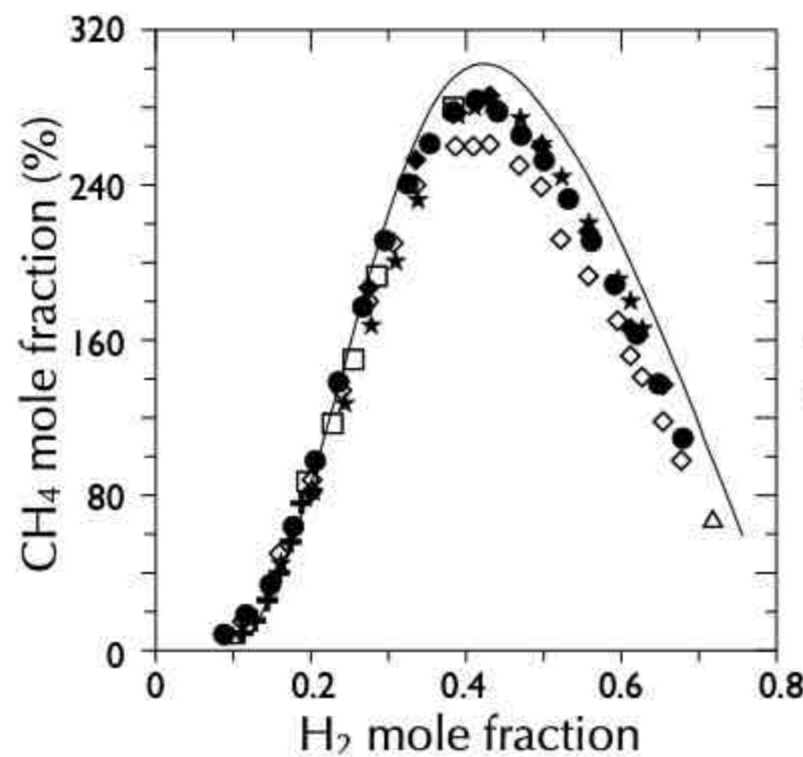

COMBUSTION MODELLING

Chemistry



Veillet et al., A&A (2024)

Roméo Veillet



Chemical network

An extensively validated C/H/O/N chemical network

Major production reaction in:

— V20

— V24

— V20 & V24

— Exclusive to V24

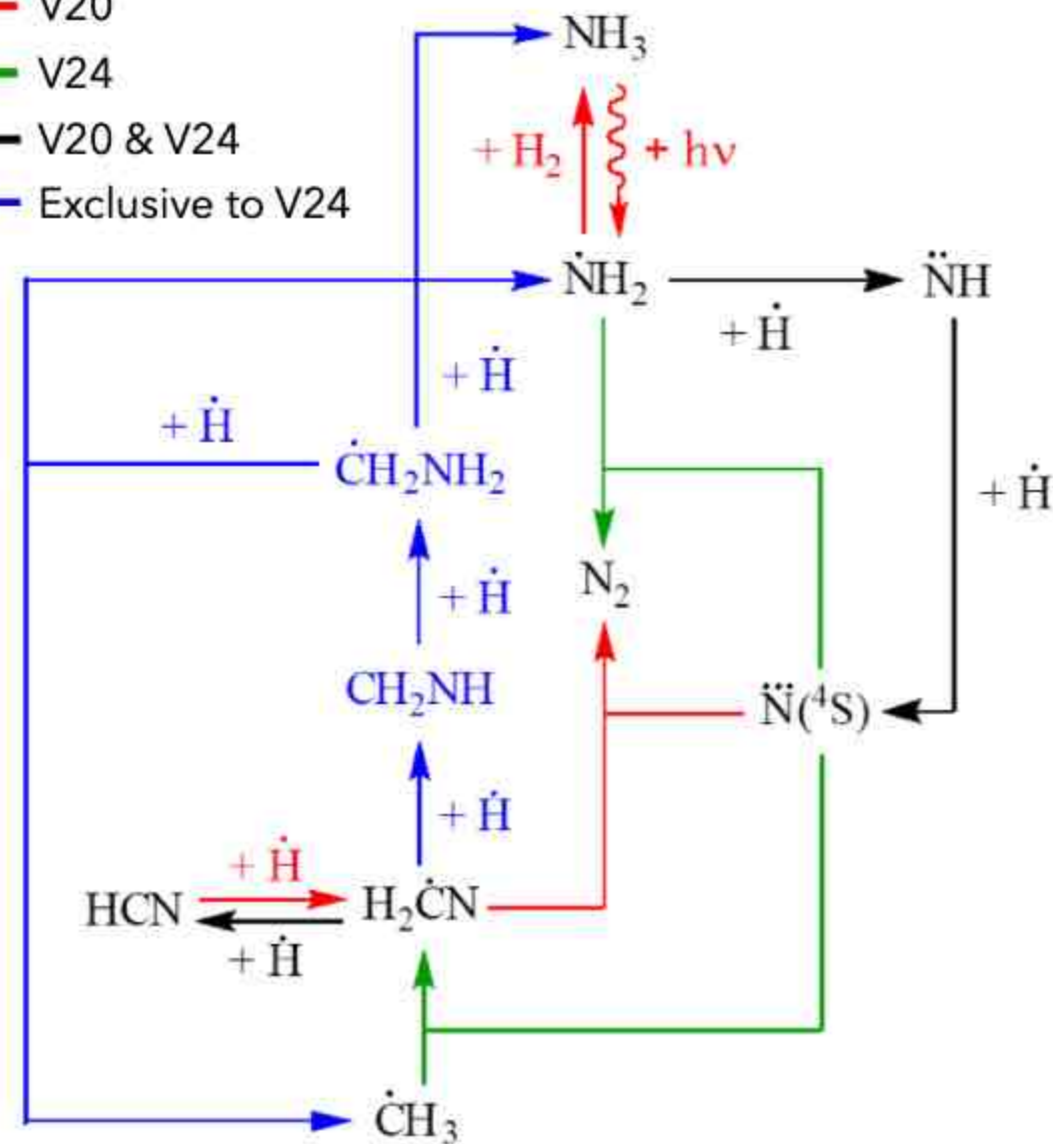

PHOTO/THERMOCHEMICAL MODELLING

Chemistry



Chemical network

An extensively validated C/H/O/N chemical network

Veillet et al., A&A (2024)

Roméo Veillet

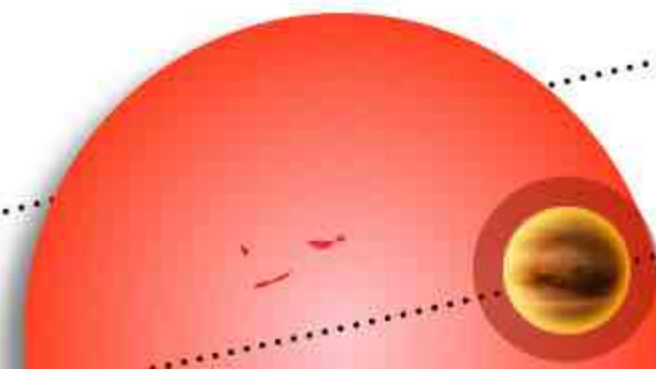
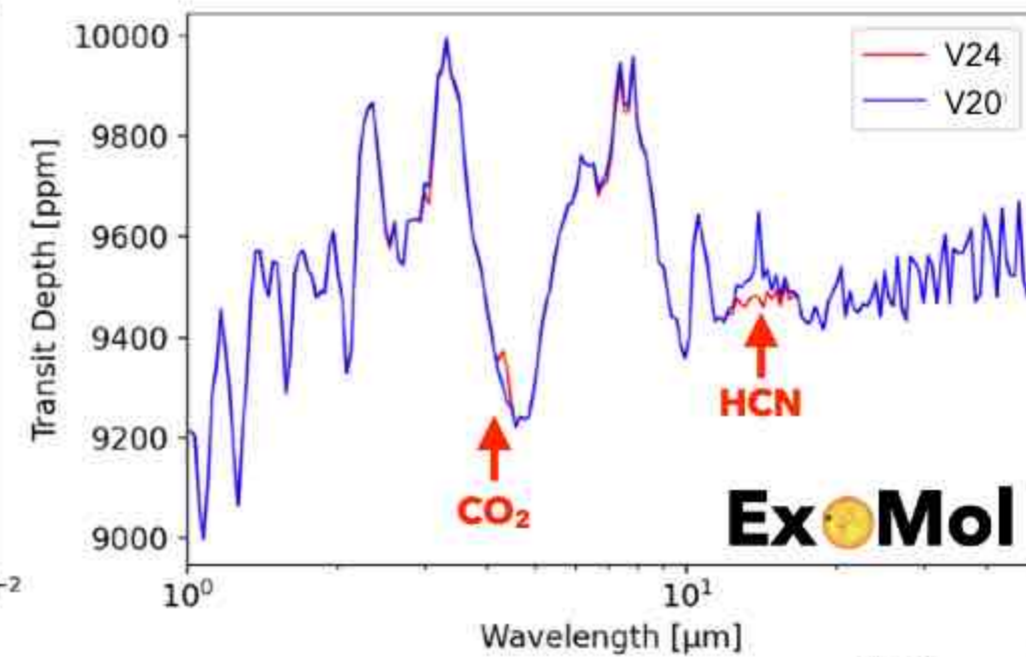
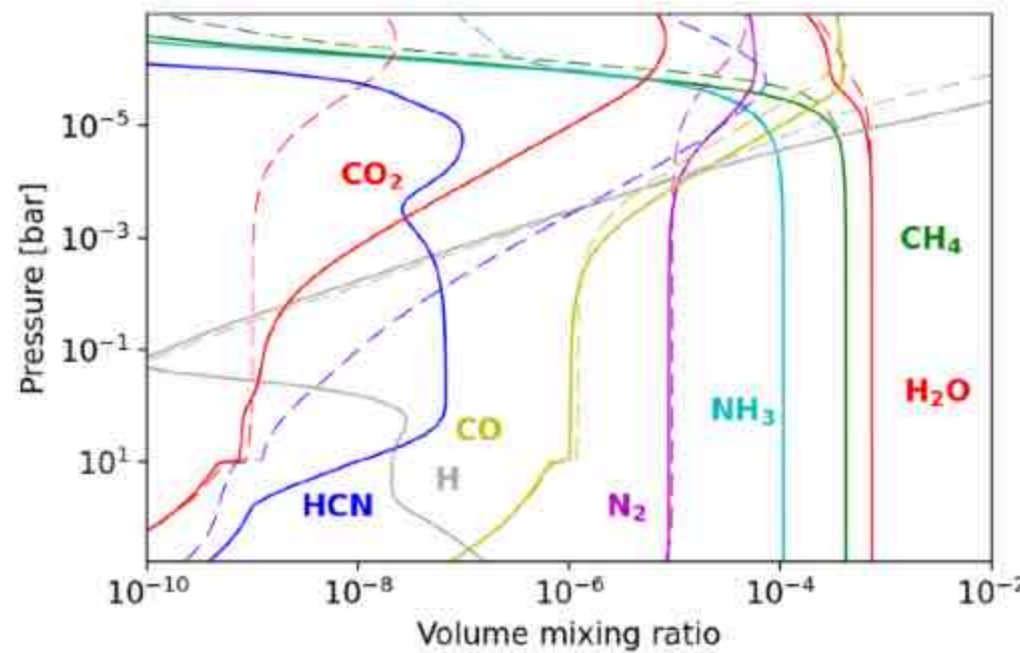

GJ 436b, 1x solar metallicity

COMBUSTION MODELLING

Chemistry



Veillet et al., under review

Roméo Veillet



Chemical network

An extensively validated C/H/O/N/S chemical network

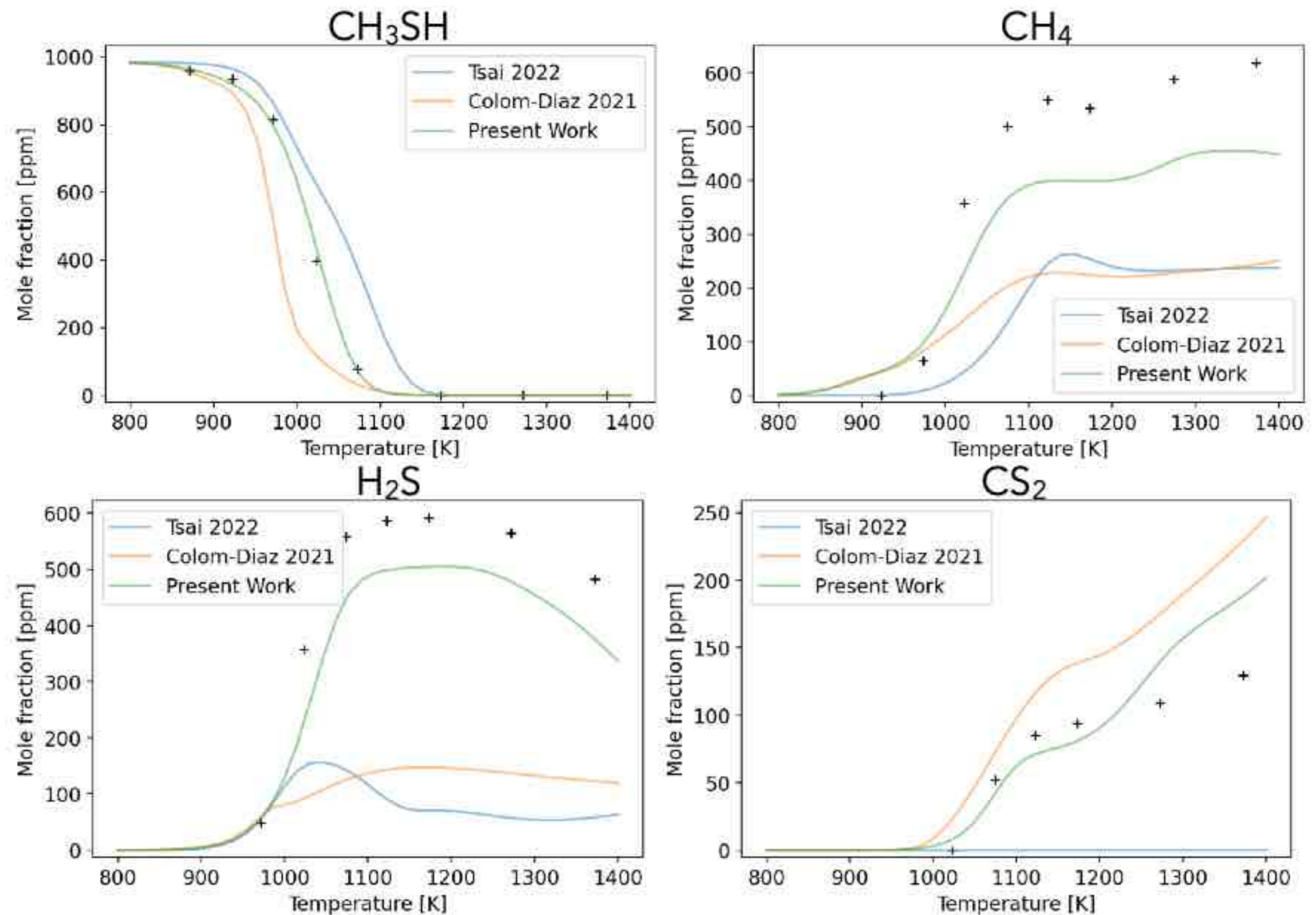

PHOTO/THERMOCHEMICAL MODELLING

Chemistry



Chemical kinetics

An extensively validated C/H/O/N/S chemical network

Veillet et al., *under review*

Roméo Veillet

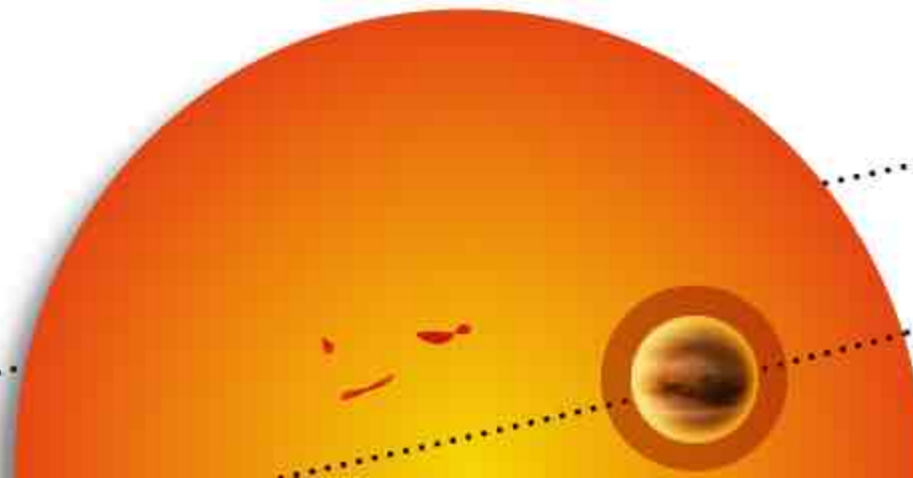
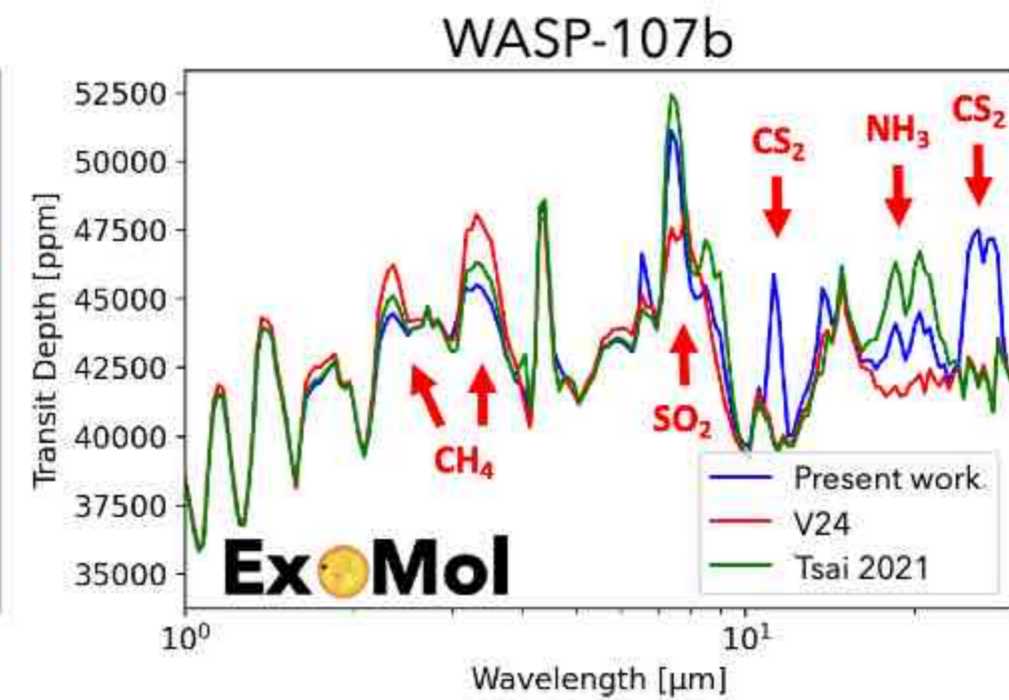
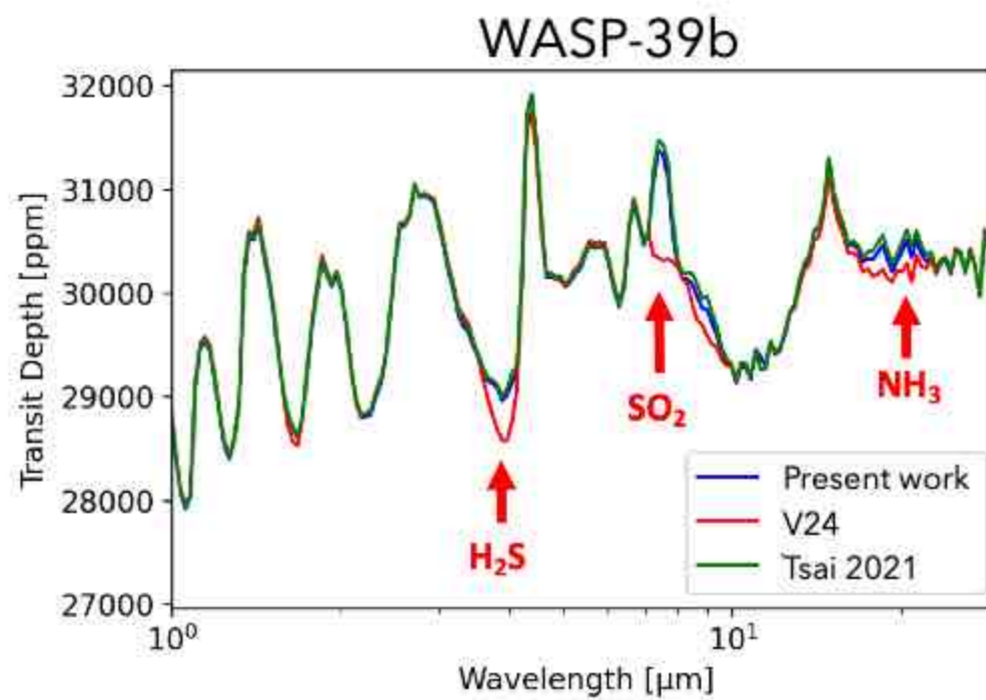

(EXO)CLIMATE SIMULATIONS ?

Met Office Unified Model

Chemistry



Chemical kinetics

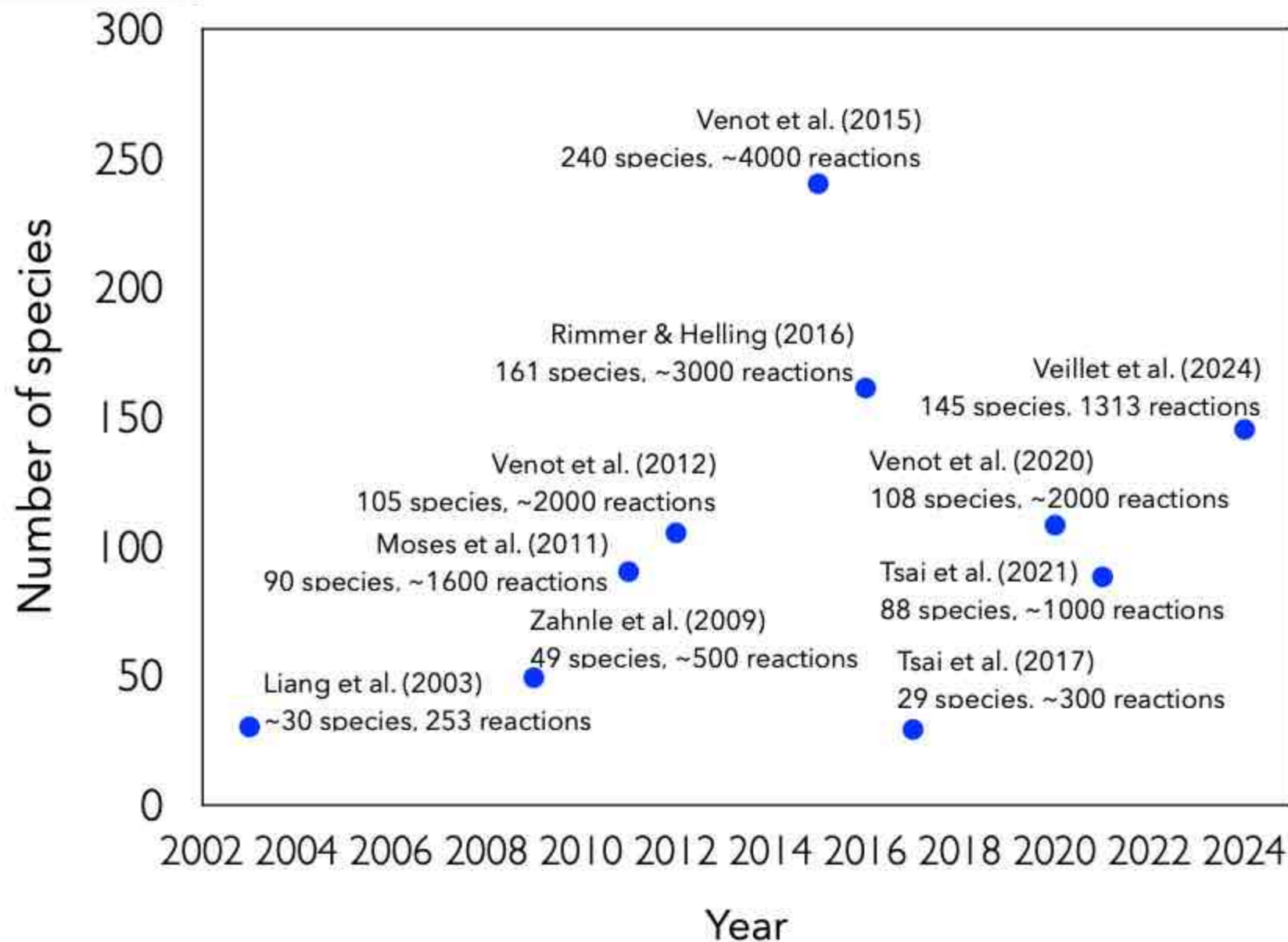

(EXO)CLIMATE SIMULATIONS ?

Met Office Unified Model

Chemistry

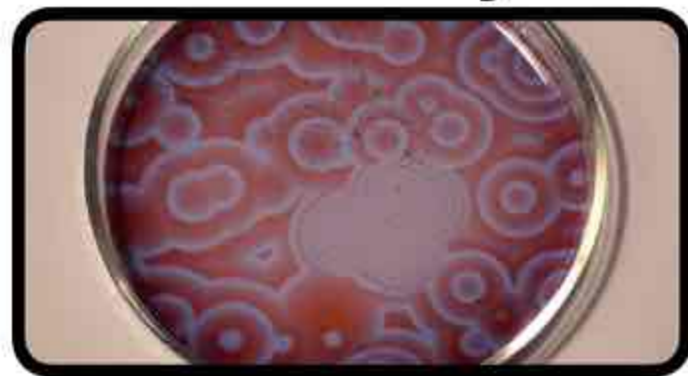

Chemical kinetics

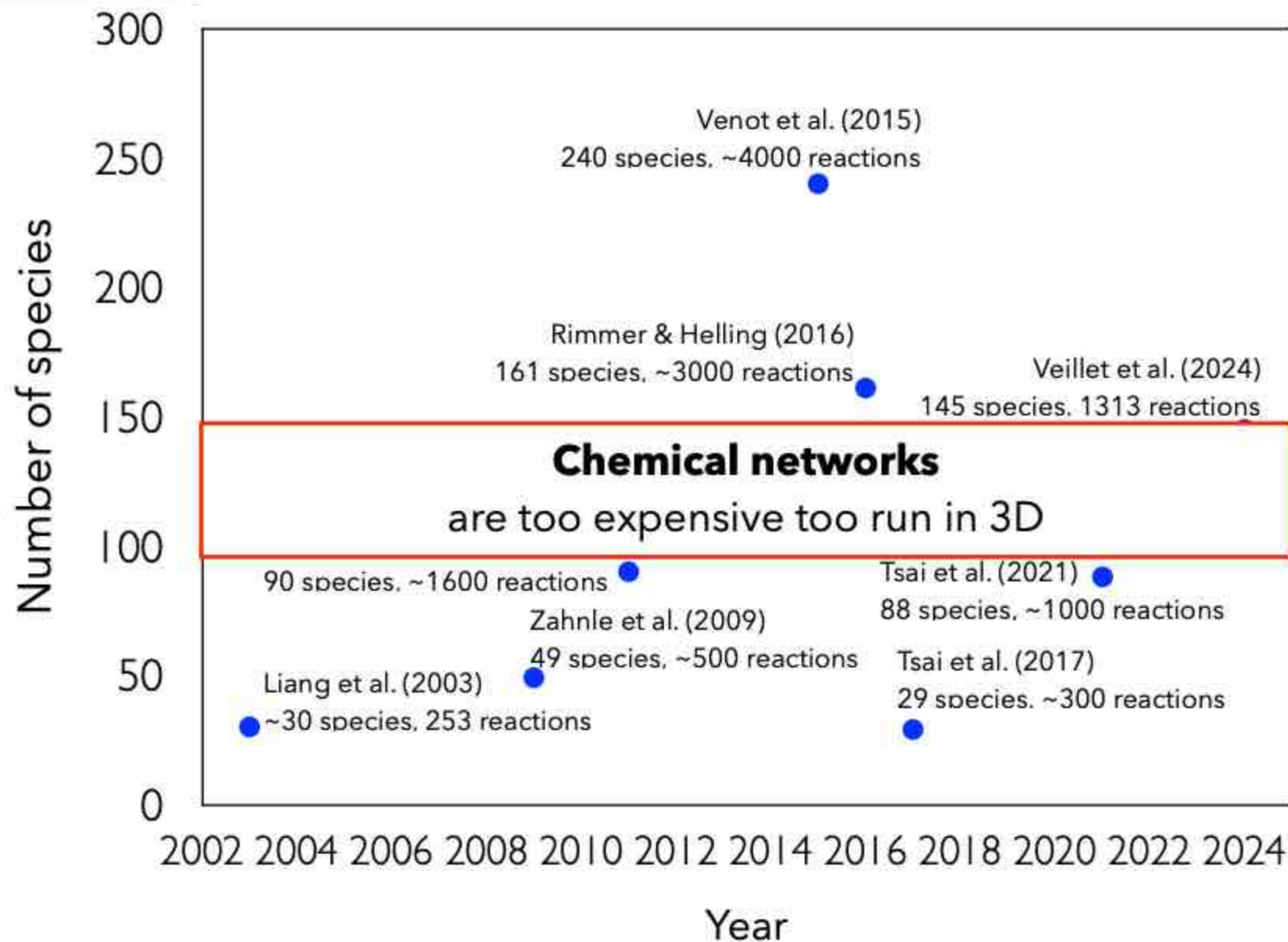

(EXO)CLIMATE SIMULATIONS ?

Met Office Unified Model

Chemistry



Chemical kinetics

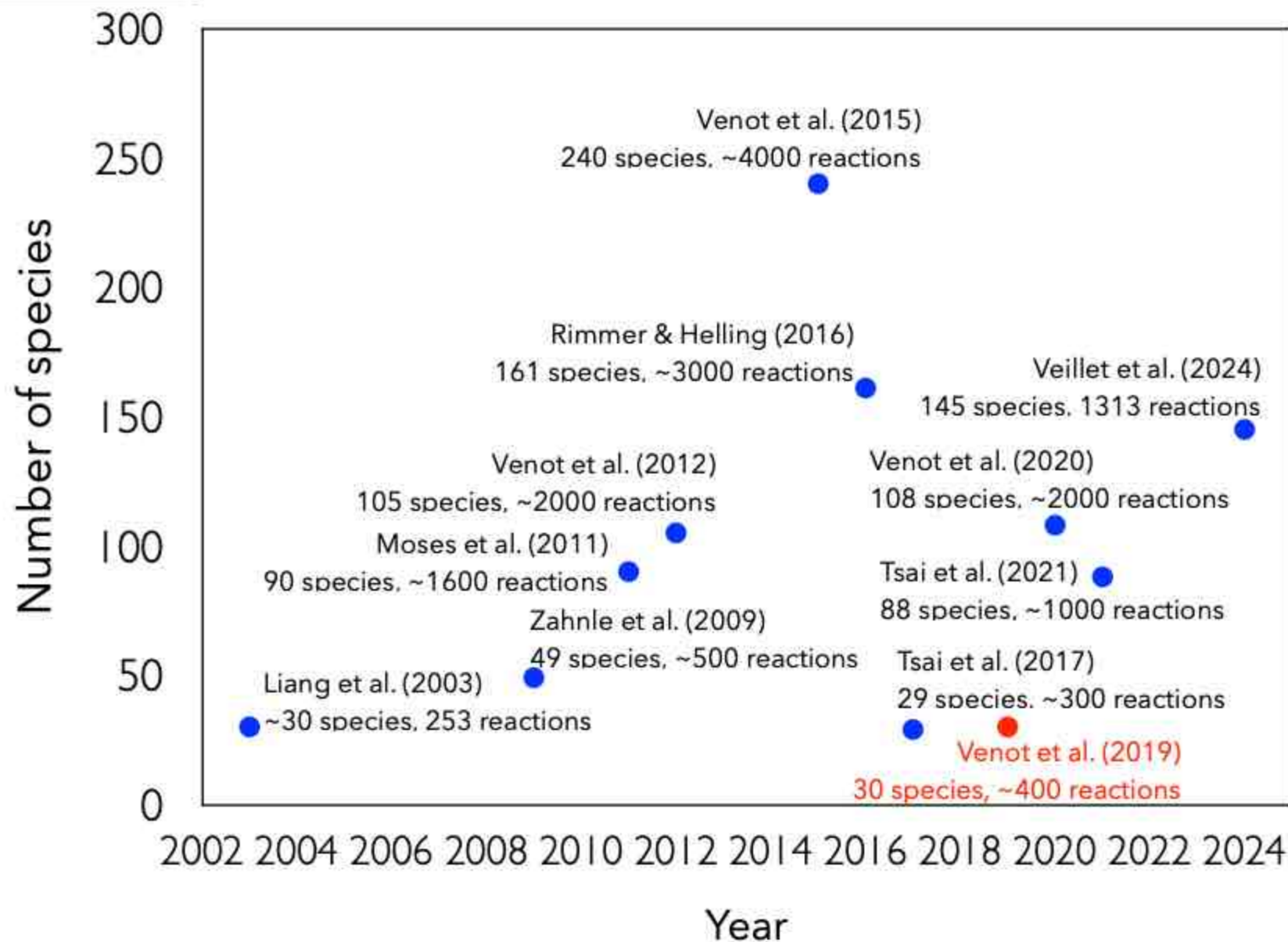

PHOTO/THERMOCHEMICAL MODELLING

Chemistry



Hébrard et al., Proc Combust Inst. (2015)

Chemical kinetics

Uncertainty analysis

				$F(300K)$	g	
740.	O2+B5CH2=R5CHO+R2OH	4.30E+10	0.0	-500.0	1.26	0
741.	O2+B5CH2=CO2+H2	6.90E+11	0.0	500.0	1.26	0
742.	O2+B5CH2=>CO2+R1H+R1H	1.60E+12	0.0	1000.0	1.26	0
743.	O2+B5CH2=B2CO+H2O	1.90E+10	0.0	-1000.0	1.26	0
744.	O2+B5CH2=>B2CO+R2OH+R1H	8.60E+10	0.0	-500.0	1.26	0
745.	O2+B5CH2=HCHO+B1O	1.00E+14	0.0	4500.0	1.26	0
746.	O2+R4CH3 (+M) =R8CH3OO (+M)	7.80E+08	1.2	0.0	1.26	0
746.		5.60E+25	-3.3	0.0	1.26	0
747.	O2+R4CH3=R7CH3O+B1O	1.30E+14	0.0	31300.0	1.47	0
748.	O2+R4CH3=HCHO+R2OH	3.00E+30	-4.7	36600.0	1.26	0
749.	O2+CH4=R4CH3+R3OOH	4.00E+13	0.0	56700.0	1.05	255
750.	O2+R9C2HT=B2CO+R5CHO	3.80E+13	-0.2	0.0	1.20	20
751.	O2+R9C2HT=R12CHCOV+B1O	9.00E+12	-0.2	0.0	1.20	20
752.	O2+C2H2T=R9C2HT+R3OOH	1.20E+13	0.0	74500.0	2.15	0
753.	O2+C2H2T=R5CHO+R5CHO	7.00E+07	1.8	30600.0	1.26	0
754.	O2+R10C2H3V=C2H2T+R3OOH	1.34E+06	1.6	-400.0	1.71	0
755.	O2+R10C2H3V=HCHO+R5CHO	4.50E+16	-1.4	1000.0	1.08	70
756.	O2+R10C2H3V=B1O+R13CH2CHO	3.30E+11	-0.3	10.0	1.26	0
757.	O2+C2H4Z=R10C2H3V+R3OOH	4.20E+13	0.0	57400.0	2.15	0
758.	O2+R11C2H5=R17C2H5OO	2.20E+10	0.8	-600.0	1.41	120
759.	O2+R11C2H5=C2H4Z+R3OOH	8.40E+11	0.0	3900.0	1.14	0
760.	O2+R11C2H5=R15C2H5O+B1O	1.20E+13	-0.2	27900.0	1.26	0
761.	O2+R11C2H5=CH3CHO+R2OH	6.00E+10	0.0	6900.0	1.14	0
762.	O2+C2H6=R11C2H5+R3OOH	6.00E+13	0.0	51700.0	1.04	255
763.	O2+R2OH=R3OOH+B1O	2.20E+13	0.0	52500.0	1.44	0
764.	O2+B2CO=CO2+B1O	2.50E+12	0.0	47700.0	1.26	0
765.	O2+R5CHO=B2CO+R3OOH	7.60E+12	0.0	410.0	1.24	60
766.	O2+HCHO=R5CHO+R3OOH	2.00E+13	0.0	38800.0	1.26	0
767.	O2+R7CH3O=HCHO+R3OOH	2.20E+10	0.0	1700.0	1.26	0
768.	O2+R6CH2OH=HCHO+R3OOH	1.20E+12	0.0	0.0	1.26	0
769.	O2+CH3OH=R6CH2OH+R3OOH	2.00E+13	0.0	44900.0	2.15	0
770.	O2+R12CHCOV=>B2CO+B2CO+R2OH	1.50E+12	0.0	2500.0	1.71	0
771.	O2+R14CH3CO=R18CH3COOO	2.40E+12	0.0	0.0	1.21	30
772.	O2+R13CH2CHO=>HCHO+R2OH+B2CO	5.90E+09	0.0	-1400.0	1.17	0

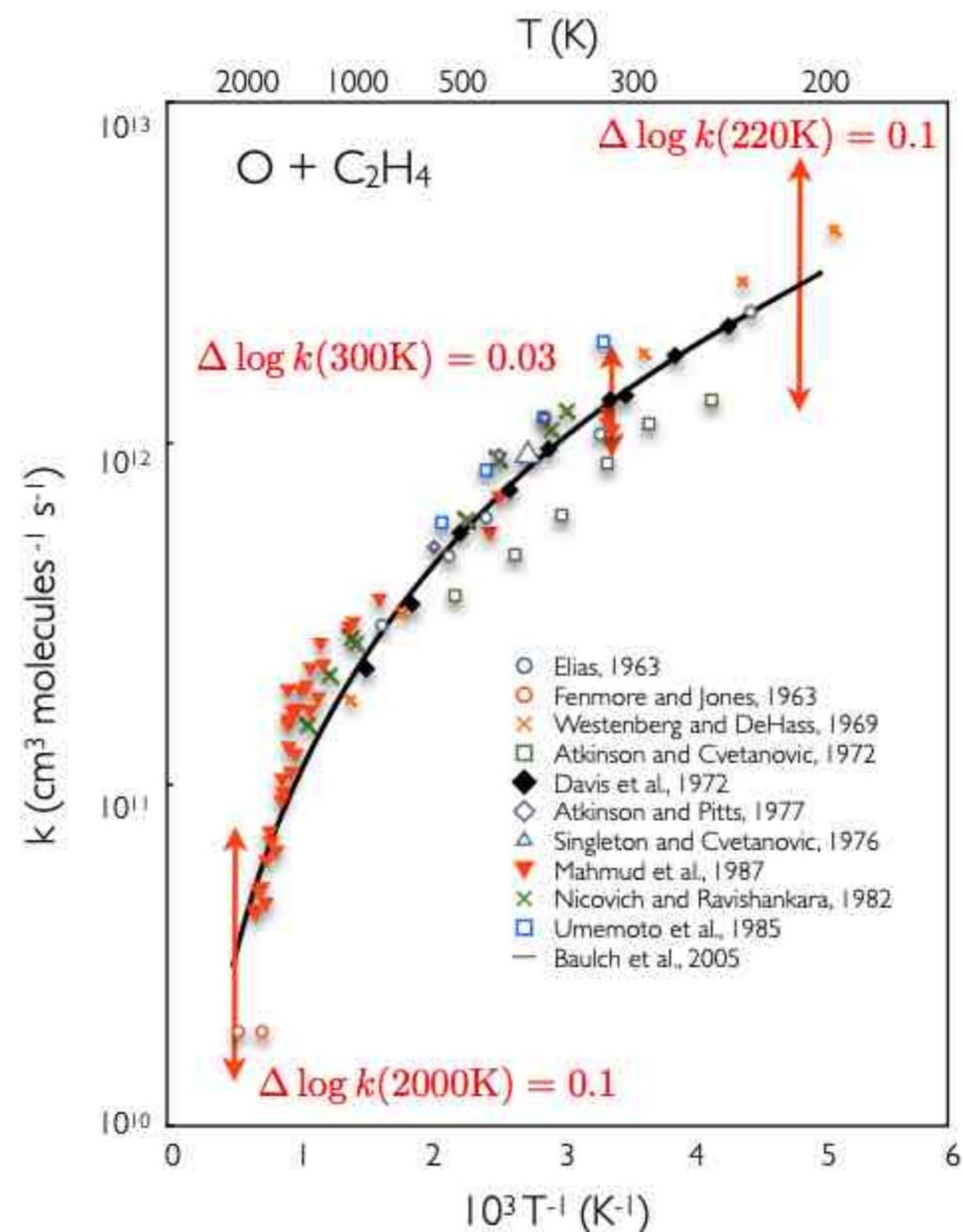

PHOTO/THERMOCHEMICAL MODELLING

Chemistry



Chemical kinetics

Uncertainty propagation

Venot et al., A&A (2019)

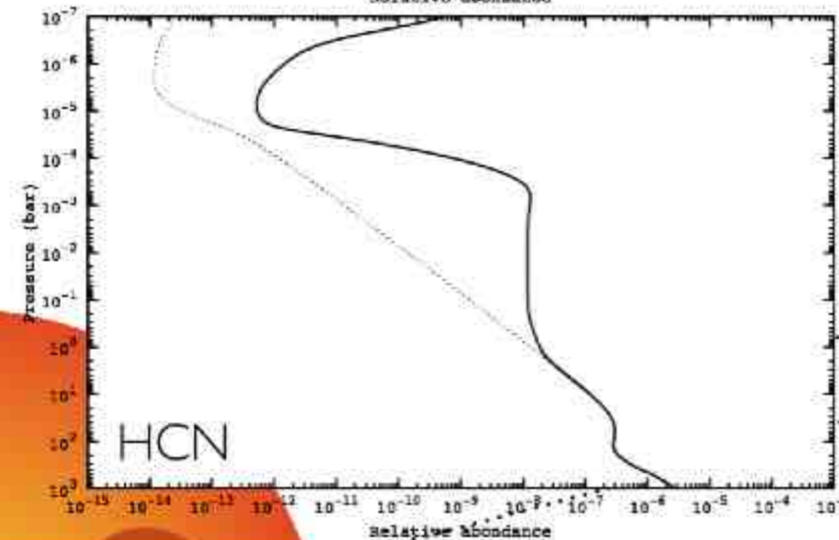
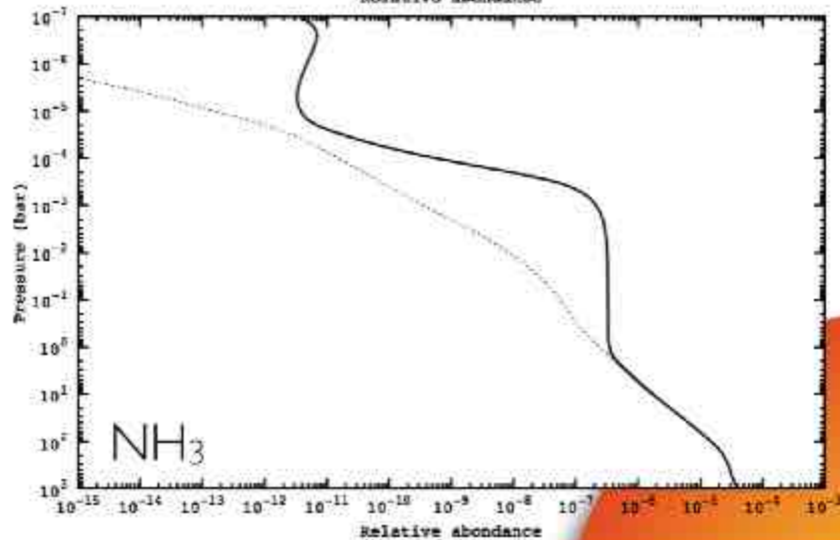
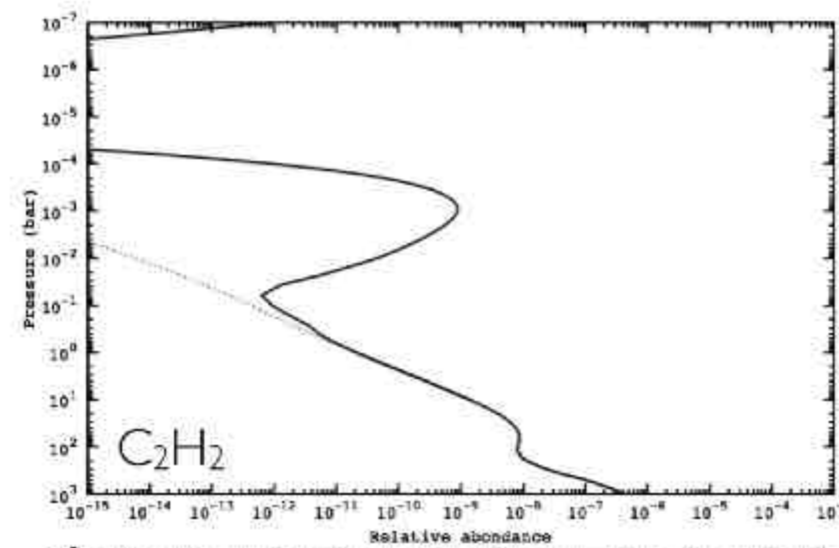
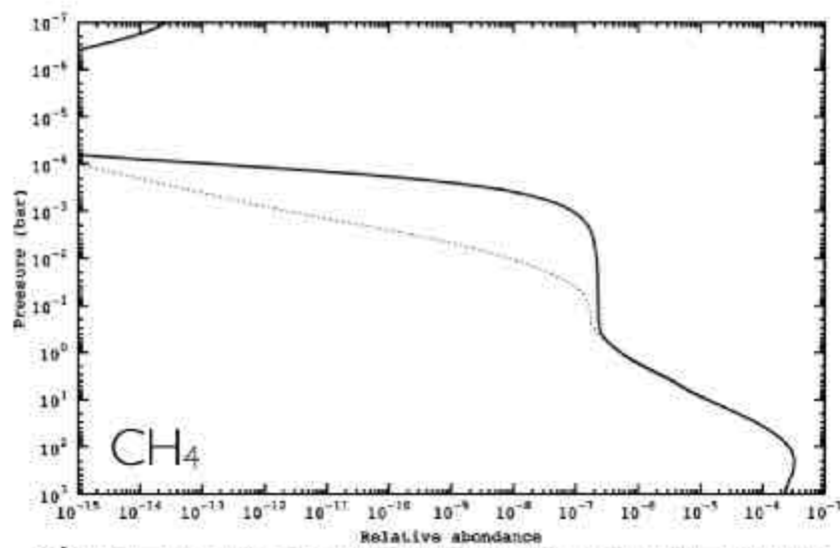

PHOTO/THERMOCHEMICAL MODELLING

Chemistry



Chemical kinetics

Uncertainty propagation

Venot et al., A&A (2019)

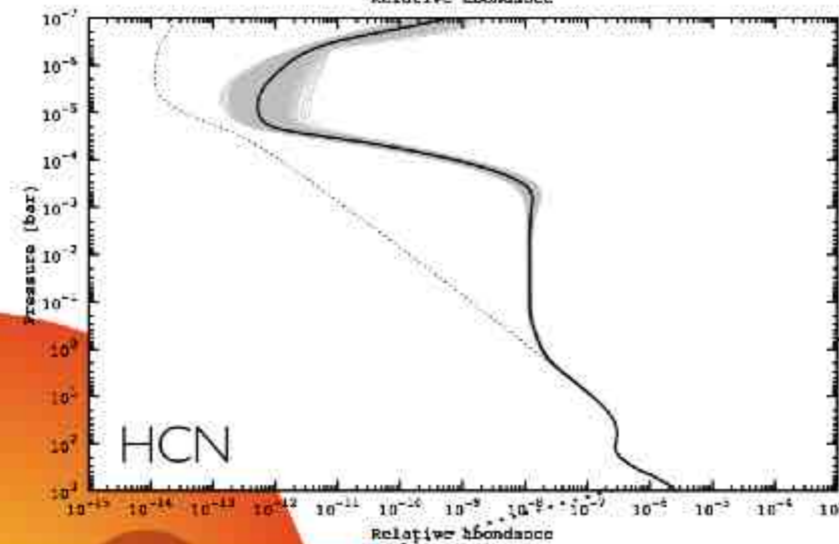
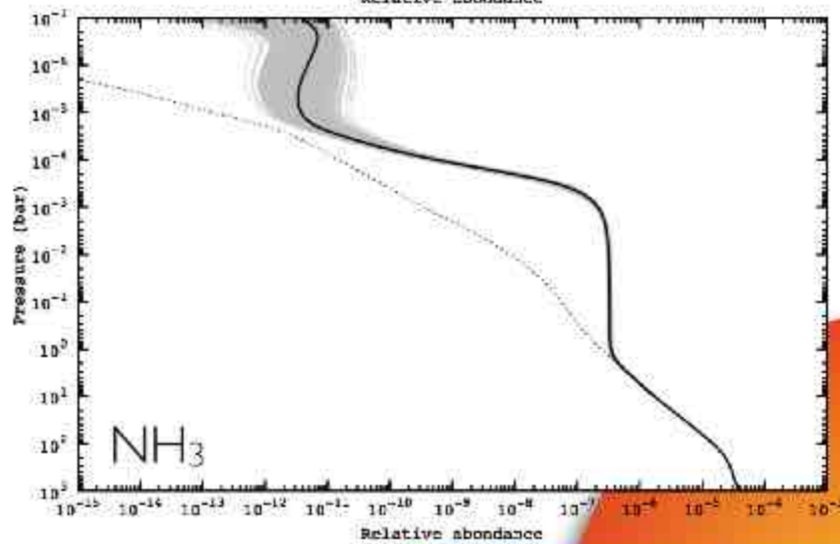
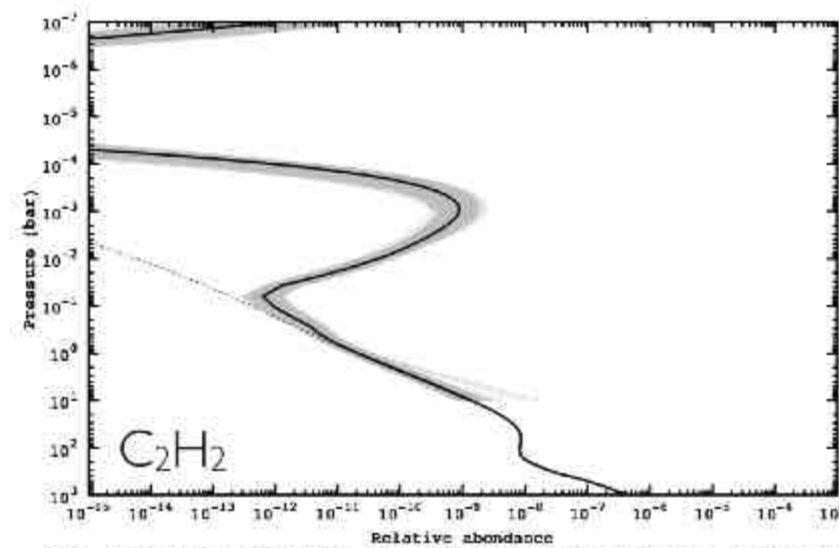
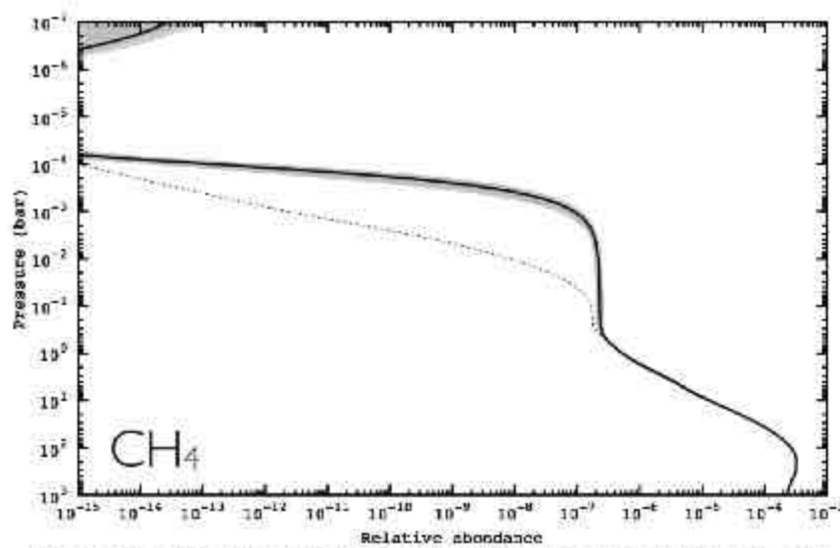

PHOTO/THERMOCHEMICAL MODELLING

Chemistry



Chemical kinetics

Sensitivity analysis

Hébrard et al., Proc Combust Inst. (2015)

1	19	$\text{CH}_3 + \text{C} = \text{C}_2\text{H}_2 + \text{H}$	27/ 90	1928.5km	0.6434
2	21	$\text{CH}_3 + \text{CH}_3 = \text{C}_2\text{H}_6 + \text{H}$	43/ 90	1155.7km	-0.8823
3	39	$\text{C}_2\text{H}_3 + \text{H} = \text{C}_2\text{H}_2 + \text{H}_2$	33/ 90	1638.7km	0.5471
4	71	$\text{C}_2\text{H}_3 + \text{C}_2\text{H}_3 = \text{C}_2\text{H}_4 + \text{C}_2\text{H}_4$	43/ 90	1155.7km	0.5233
5	79	$\text{C}_2\text{H}_4 + \text{C}_2\text{H} = \text{C}_2\text{H}_2 + \text{C}_2\text{H}_5$	35/ 90	1542.1km	-0.5294
6	83	$\text{O}(^3\text{P}) + \text{H}_2 = \text{OH} + \text{H}$	18/ 90	2363.2km	0.7479
7	103	$\text{O}(^3\text{P}) + \text{C}_2\text{H} = \text{CH} + \text{CO}$	5/ 90	2991.1km	-0.5939
8	107	$\text{O}(^3\text{P}) + \text{C}_2\text{H}_2 = \text{CHCO} + \text{H}$	11/ 90	2701.3km	-0.6276
9	155	$\text{OH} + \text{C}_2\text{H}_2 = \text{C}_2\text{H} + \text{H}_2\text{O}$	35/ 90	1542.1km	-0.5064
10	261	$\text{CH}_2\text{OH} + \text{H}_2 = \text{CH}_3\text{OH} + \text{H}$	25/ 90	2025.1km	-0.5187
11	607	$\text{OOH} + \text{OOH} = \text{H}_2\text{O}_2 + \text{O}_2$	18/ 90	2363.2km	0.5409
12	787	$\text{H} + 2\text{C}_2\text{H}_3 = \text{C}_2\text{H}_6$	43/ 90	1155.7km	-0.6530
13	823	$\text{N}_2\text{O} + \text{O}(^3\text{P}) = \text{N}_2 + \text{O}_2$	43/ 90	1155.7km	-0.6509
14	1155	$\text{H}_2\text{NO} + \text{NH}_2 = \text{HNO} + \text{NH}_3$	18/ 90	2363.2km	0.5457
15	1535	$\text{CH}_3\text{O} + \text{NO} = \text{H}_2\text{CO} + \text{HNO}$	43/ 90	1155.7km	-0.6142
16	1699	$\text{CH}_3 + \text{CH}_3 = \text{C}_2\text{H}_6$	71/ 90	-196.7km	0.6657
17	1702	$\text{C}_2\text{H}_4 = \text{CH}_3 + \text{CH}_3$	71/ 90	-196.7km	-0.6782
18	1733	$\text{C}_2\text{H}_3 = \text{C}_2\text{H}_2 + \text{H}$	35/ 90	1542.1km	-0.6788
19	1759	$\text{H} + \text{H} = \text{H}_2$	29/ 90	1831.9km	-0.5936
20	1861	$\text{C}_2\text{H}_3\text{O} = \text{CH}_3\text{CHO} + \text{H}$	43/ 90	1155.7km	0.5282
21	1911	$\text{NO}_2 + \text{O}(^3\text{P}) = \text{NO}_3$	10/ 90	2749.6km	0.5415
22	1917	$\text{CH}_4 = \text{CH}_3 + \text{H}$	2/ 90	3136.0km	0.8402

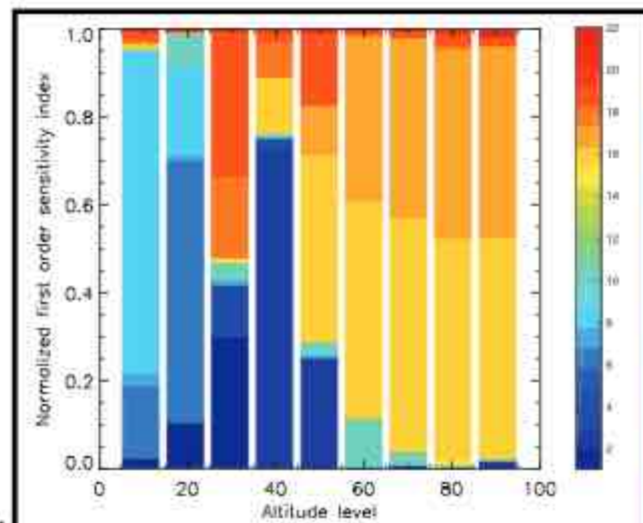
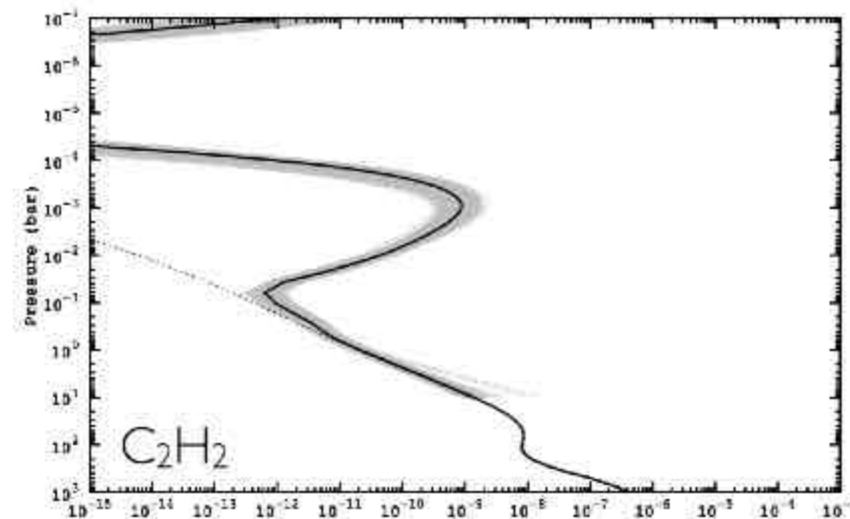

HD209458b

PHOTO/THERMOCHEMICAL MODELLING

Chemistry



Chemical kinetics
Optimisation/reduction of chemical schemes

Venot et al., A&A (2019)

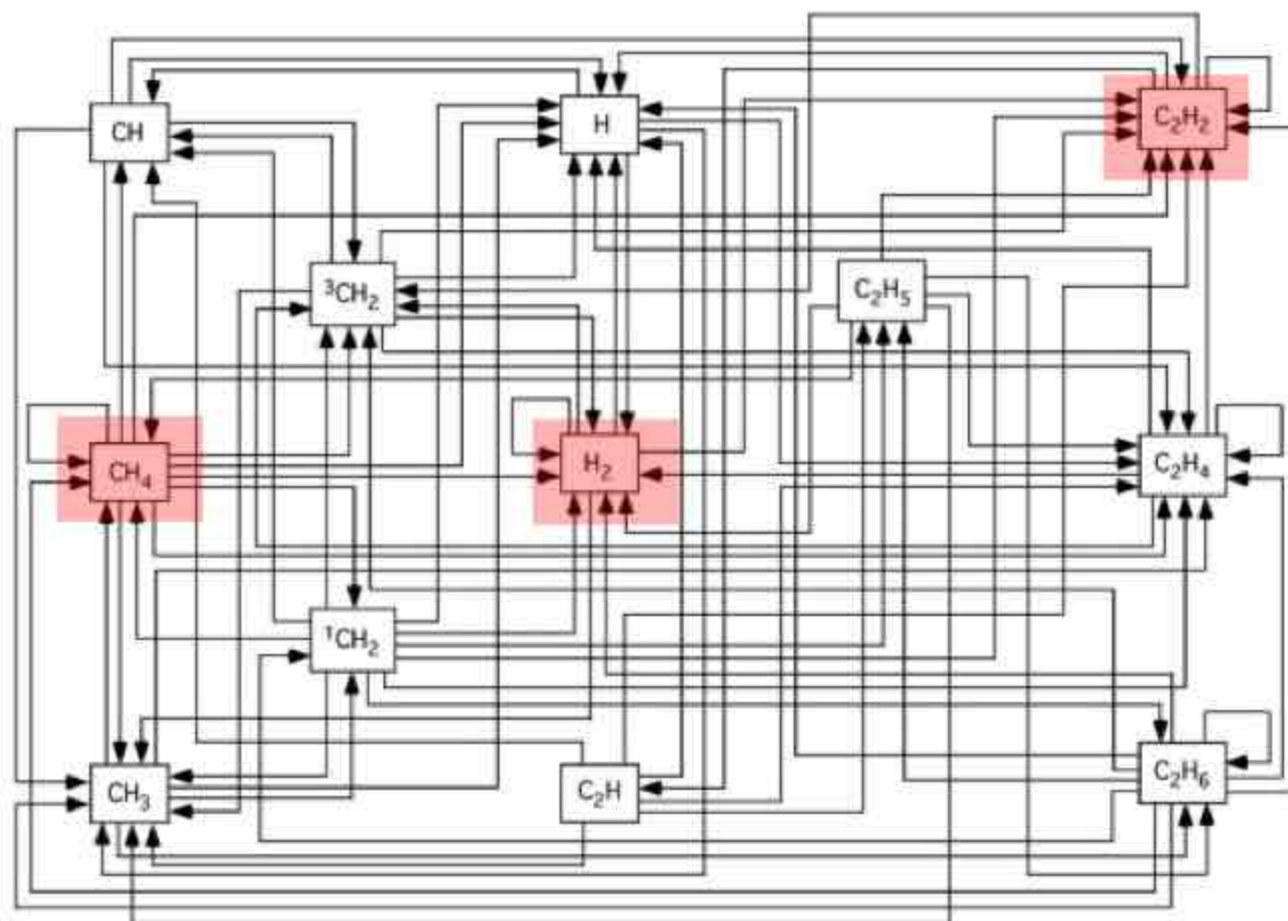

Target molecules

- Eliminate unimportant species/reactions
- Monte Carlo methods
 - Industrial software
 - By hand...

PHOTO/THERMOCHEMICAL MODELLING

Chemistry



Chemical kinetics

Optimisation/reduction of chemical schemes

ANSYS Chemkin-Pro Reaction Workbench

105 species
~2000 reactions

→

30 species
362 reactions

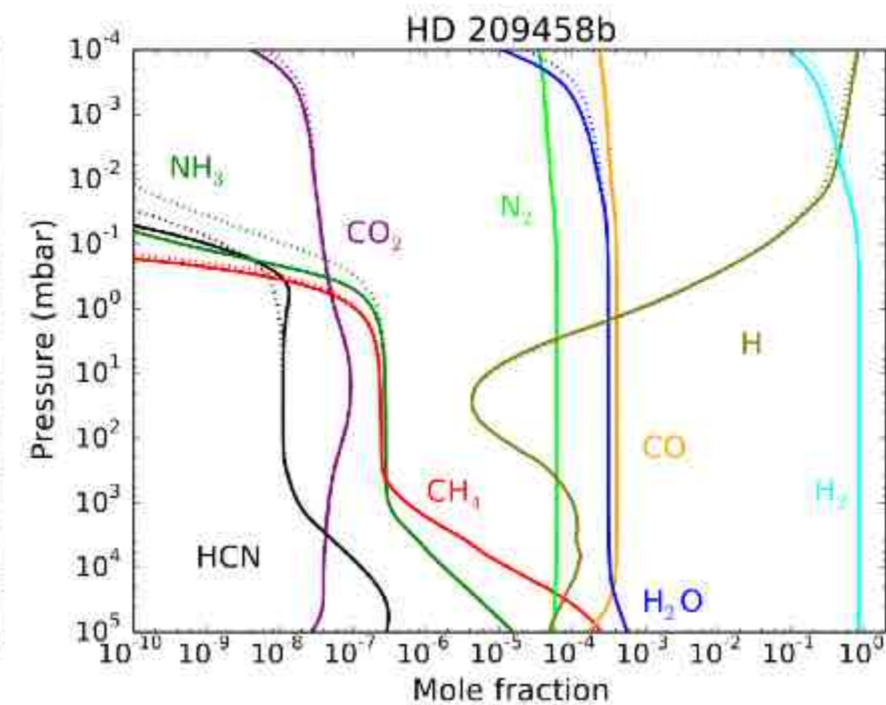
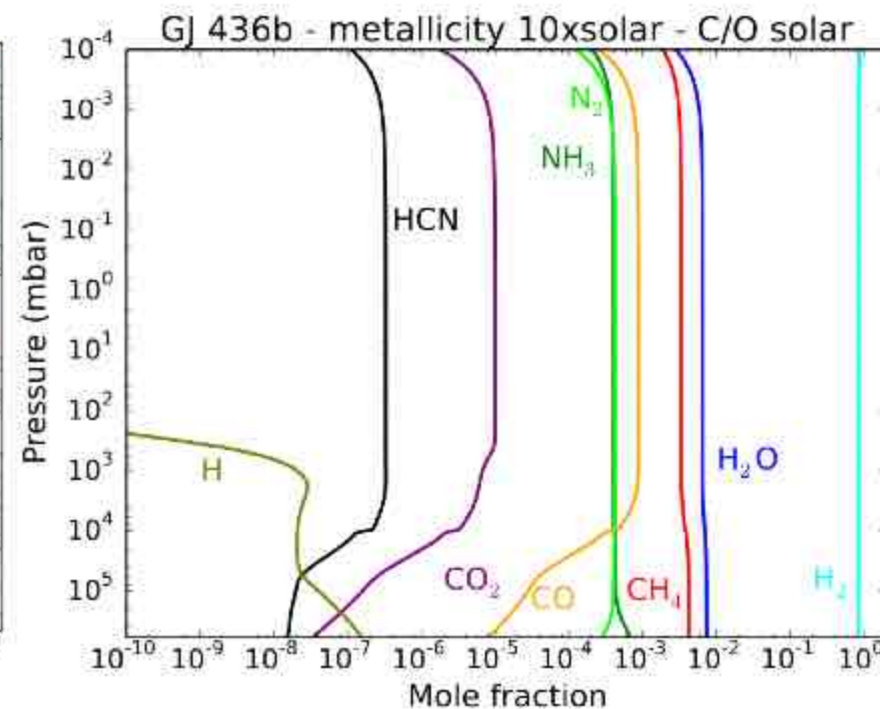
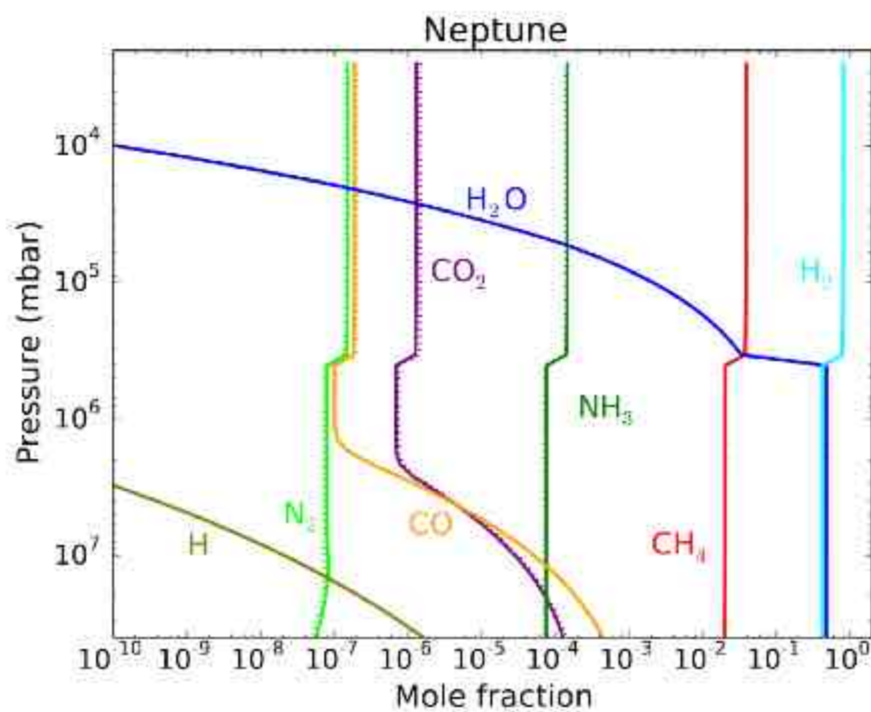

(EXO)CLIMATE SIMULATIONS

Met Office Unified Model



+

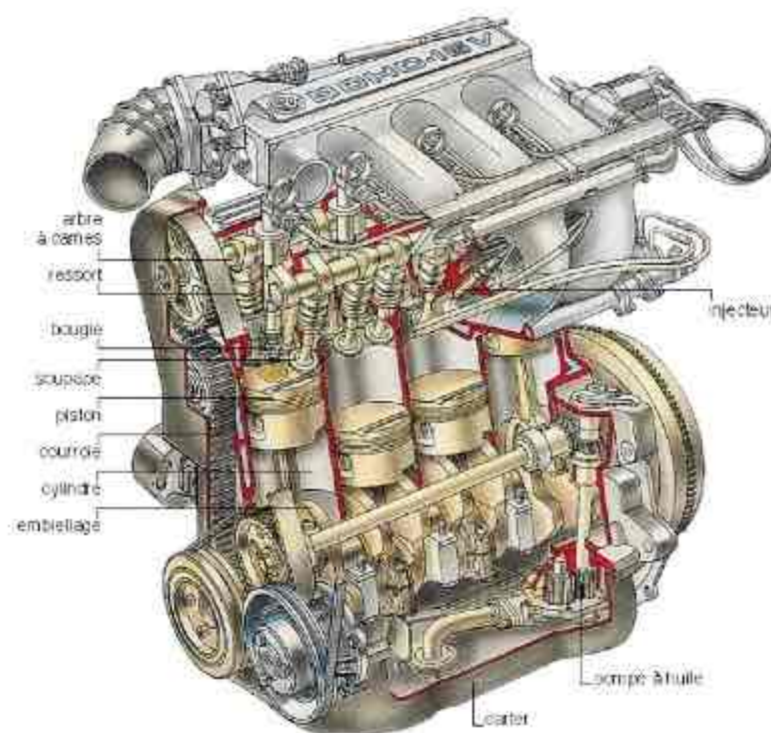

$C_0-C_2 / C_0-C_6 + NO_x$
+ PAHs + organic soots

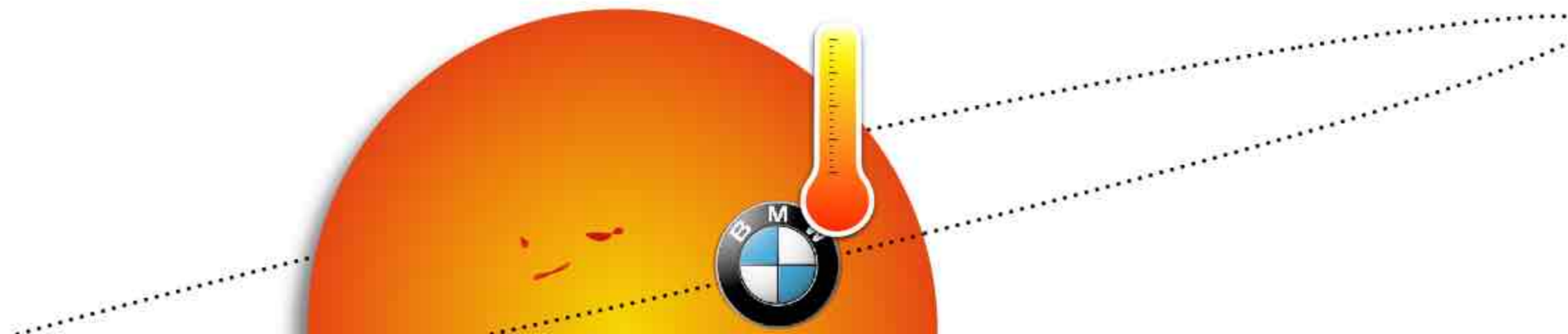

(EXO)CLIMATE SIMULATIONS

Met Office Unified Model

Chemistry



3D chemical kinetics

HAT-P-11b

HD 189733b

HD 209458b

WASP-17b



$T_{eq} = 838 \text{ K}$

$T_{eq} = 1191 \text{ K}$

$T_{eq} = 1459 \text{ K}$

$T_{eq} = 1755 \text{ K}$

Maria Zamyatina

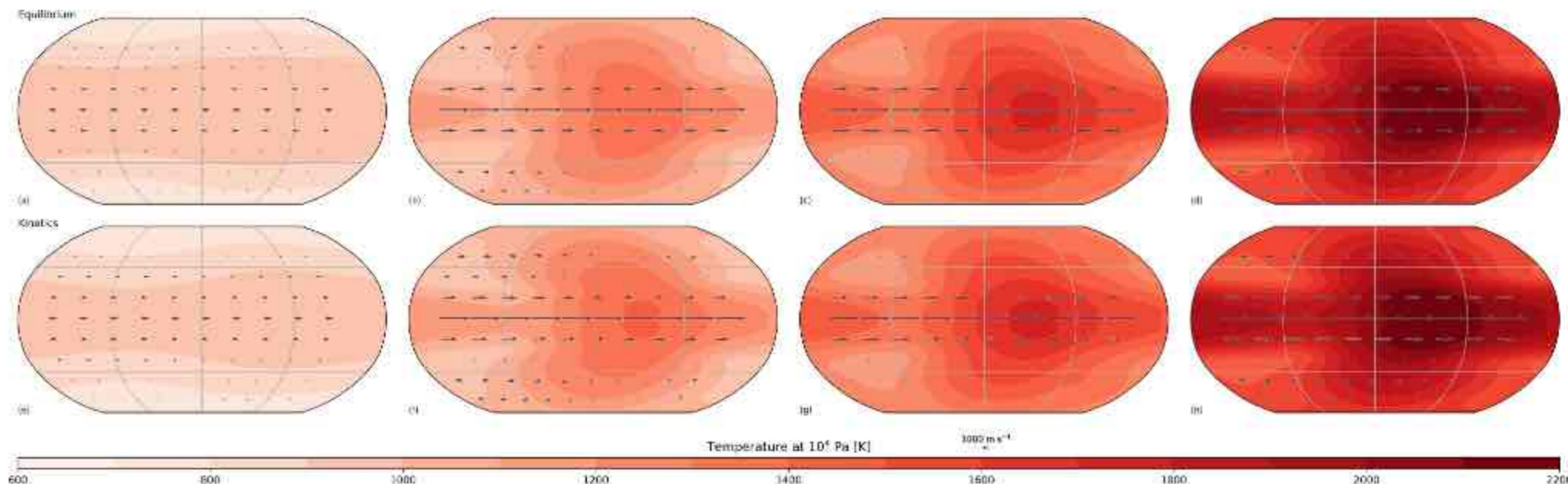

Temperature and horizontal wind speed at 10^4 Pa

(EXO)CLIMATE SIMULATIONS

Met Office Unified Model

Chemistry



3D chemical kinetics

HAT-P-11b

HD 189733b

HD 209458b

WASP-17b



$T_{eq} = 838$ K

$T_{eq} = 1191$ K

$T_{eq} = 1459$ K

$T_{eq} = 1755$ K

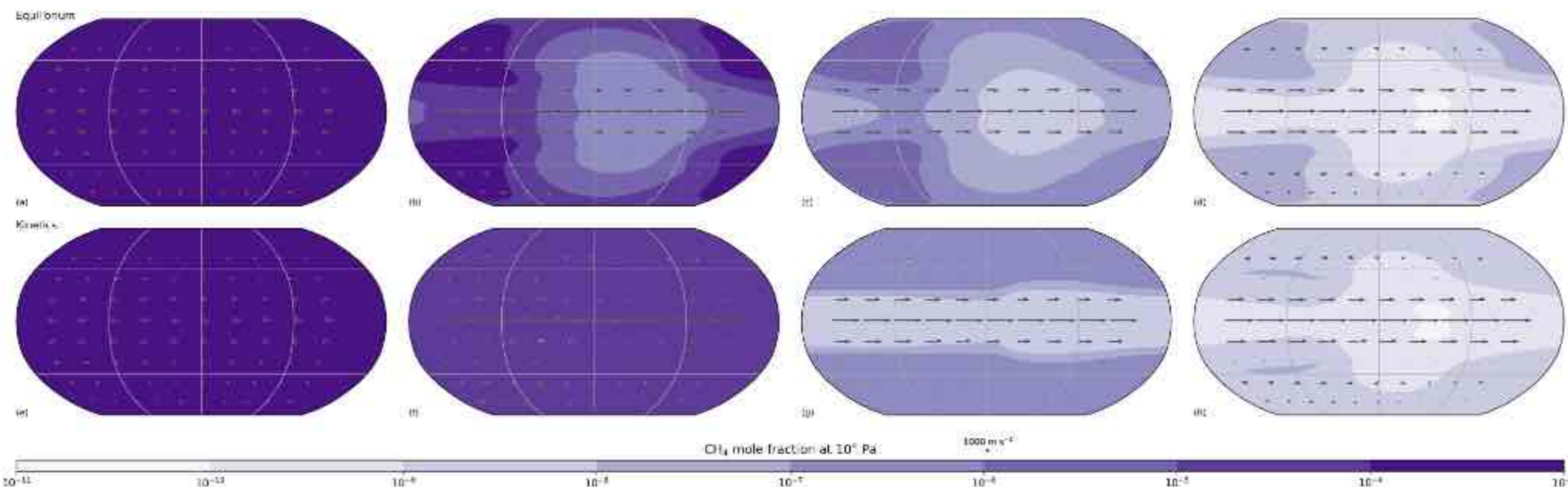

CH₄ mole fraction and horizontal wind speed at 10⁴ Pa

Drummond et al., A&A (2020)
Zamyatina et al., MNRAS (2023)

Maria Zamyatina



(EXO)CLIMATE SIMULATIONS

Met Office Unified Model

Chemistry



Drummond et al., A&A (2020)
Zamyatina et al., MNRAS (2023)

Maria Zamyatina



3D chemical kinetics

HAT-P-11b



$T_{eq} = 838$ K

HD 189733b



$T_{eq} = 1191$ K

HD 209458b



$T_{eq} = 1459$ K

WASP-17b



$T_{eq} = 1755$ K

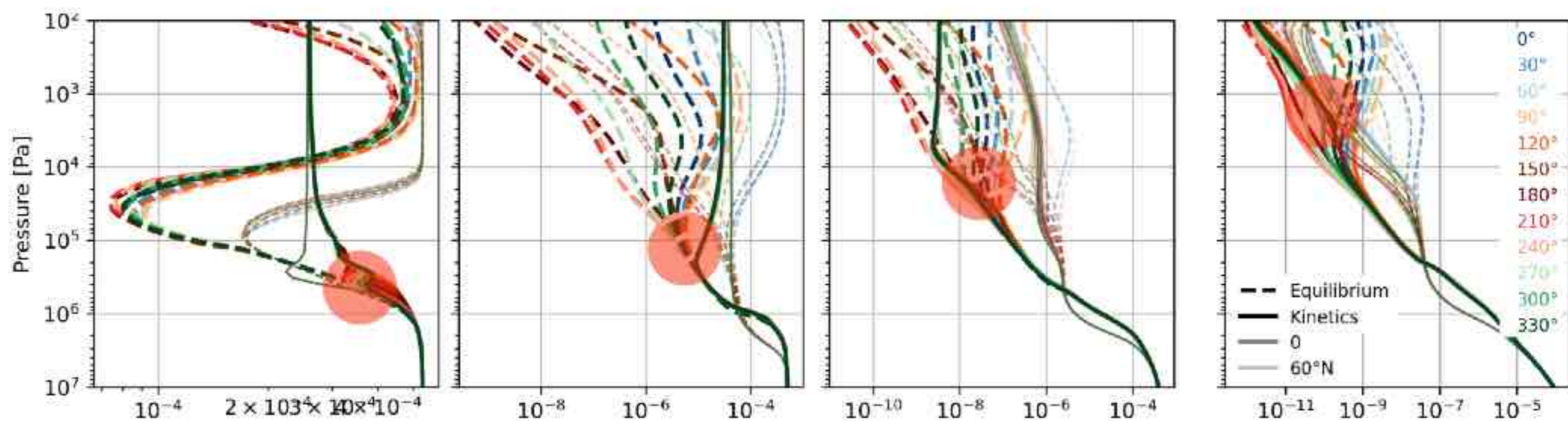

CH₄ abundance profile at 0° and 60° N

(EXO)CLIMATE SIMULATIONS

Met Office Unified Model

Chemistry



3D chemical kinetics

Impact on the transmission spectrum

Zamyatina et al., MNRAS (2023)

Maria Zamyatina

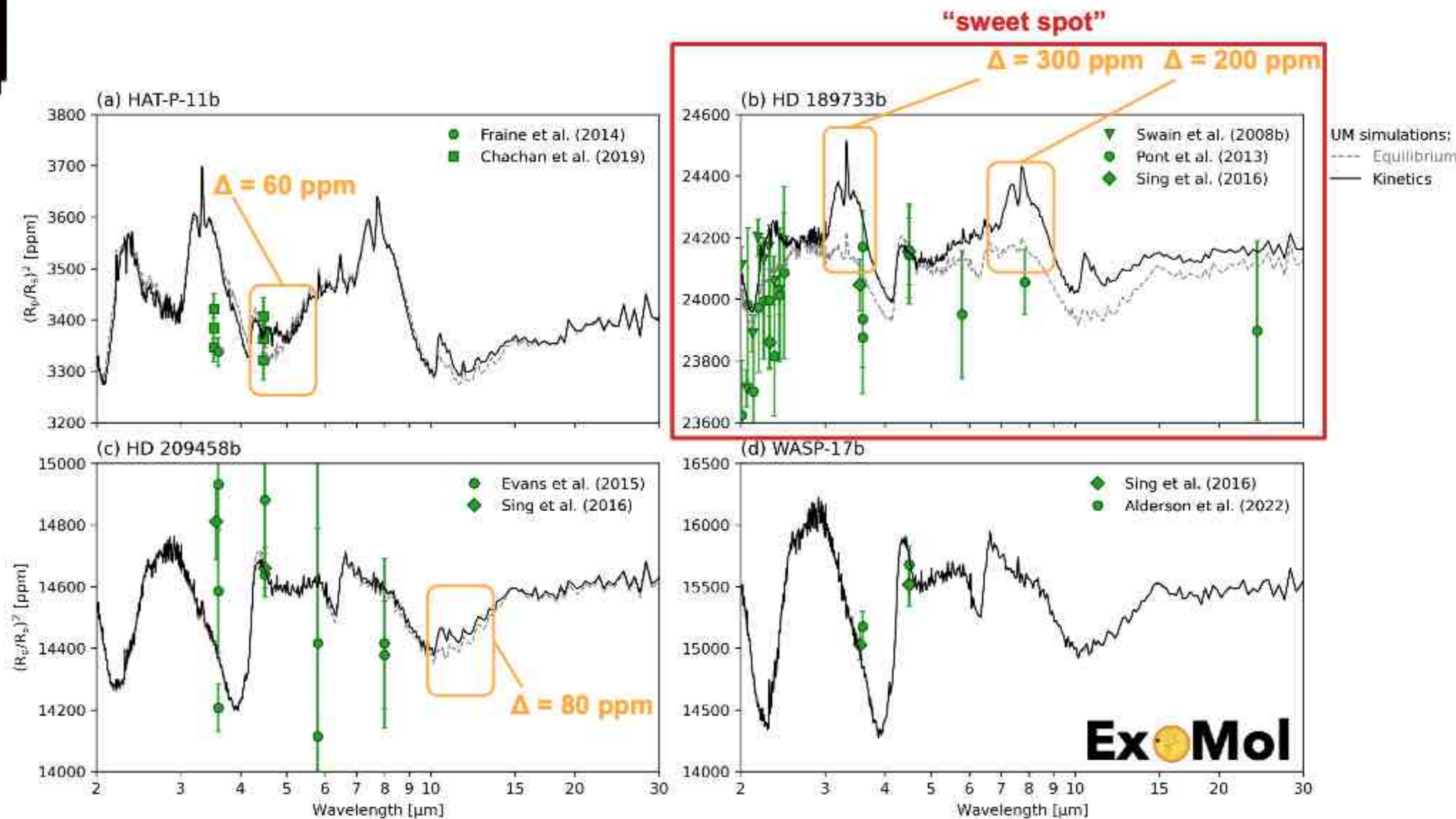

ExoMol

(EXO)CLIMATE SIMULATIONS

Met Office Unified Model

Chemistry



Zamyatina et al., MNRAS (2023)

Maria Zamyatina



3D chemical kinetics

Impact on the phase curve

HD 189733b



$T_{eq} = 1191$ K

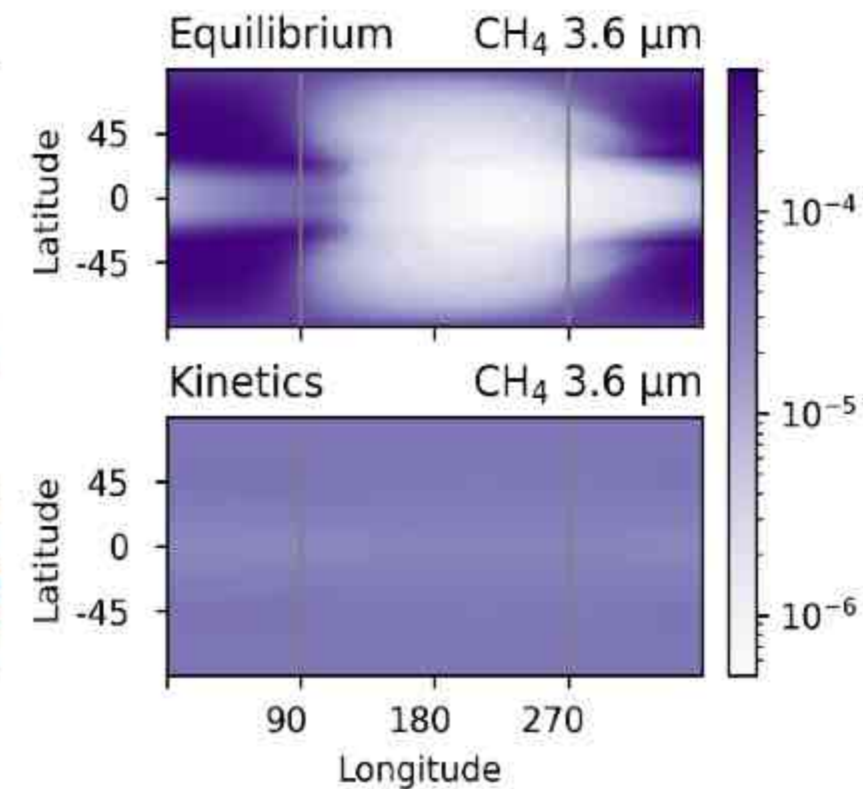
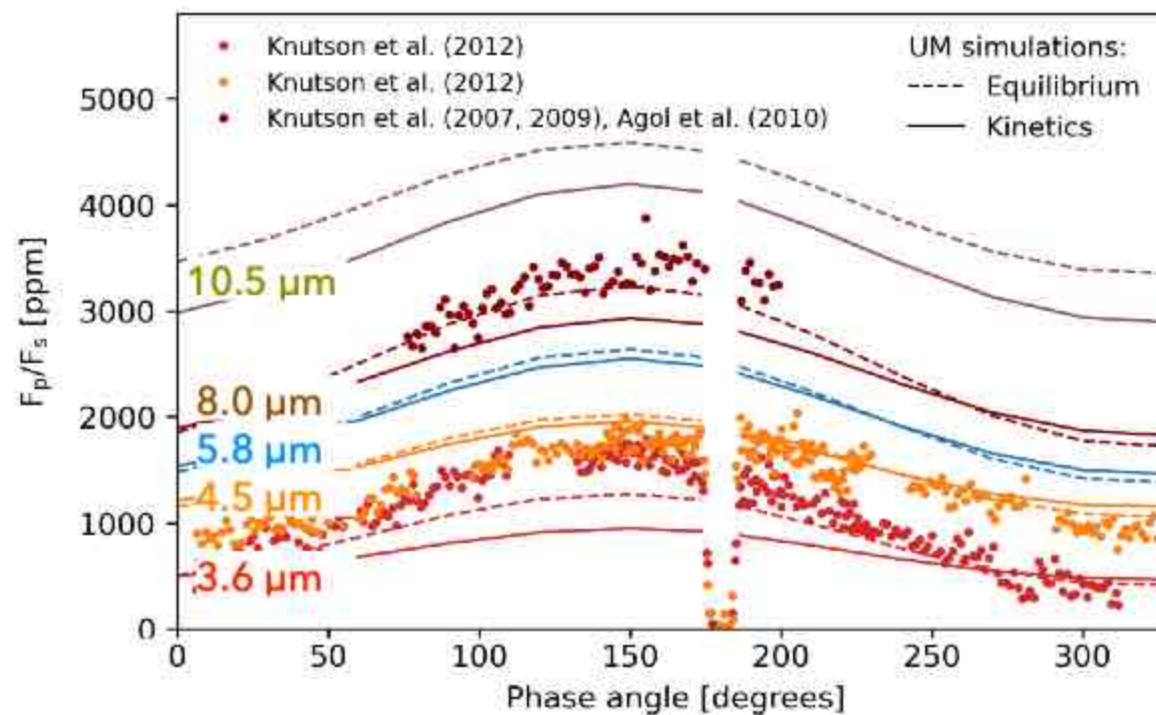

(EXO)CLIMATE SIMULATIONS

Met Office Unified Model

Chemistry



Zamyatina et al., MNRAS (2024)

Maria Zamyatina



3D chemical kinetics

HAT-P-11b



$T_{eq} = 838 \text{ K}$

HD 189733b



$T_{eq} = 1191 \text{ K}$

WASP-96b



$T_{eq} = 1285 \text{ K}$

HD 209458b



$T_{eq} = 1459 \text{ K}$

WASP-17b



$T_{eq} = 1755 \text{ K}$

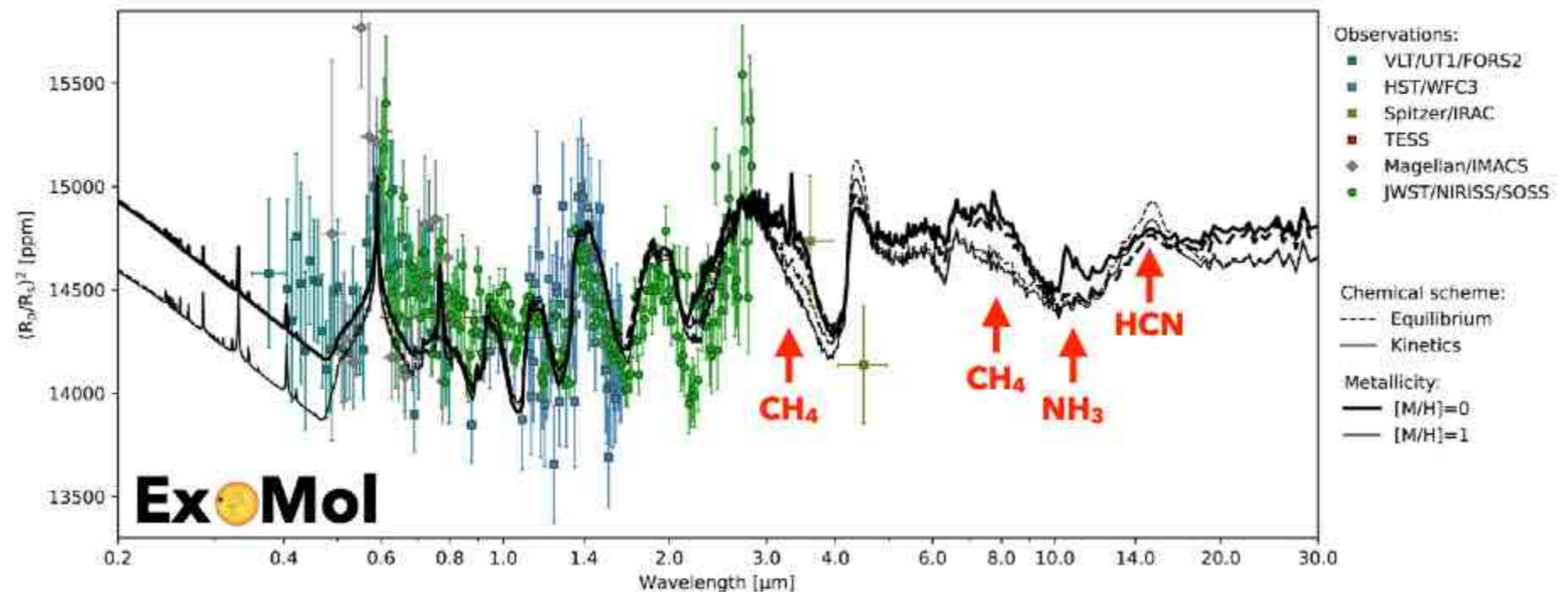

(EXO)CLIMATE SIMULATIONS

Met Office Unified Model

Chemistry



Mukherjee et al., *under review*

Harry Baskett



3D chemical kinetics

Limb asymmetry

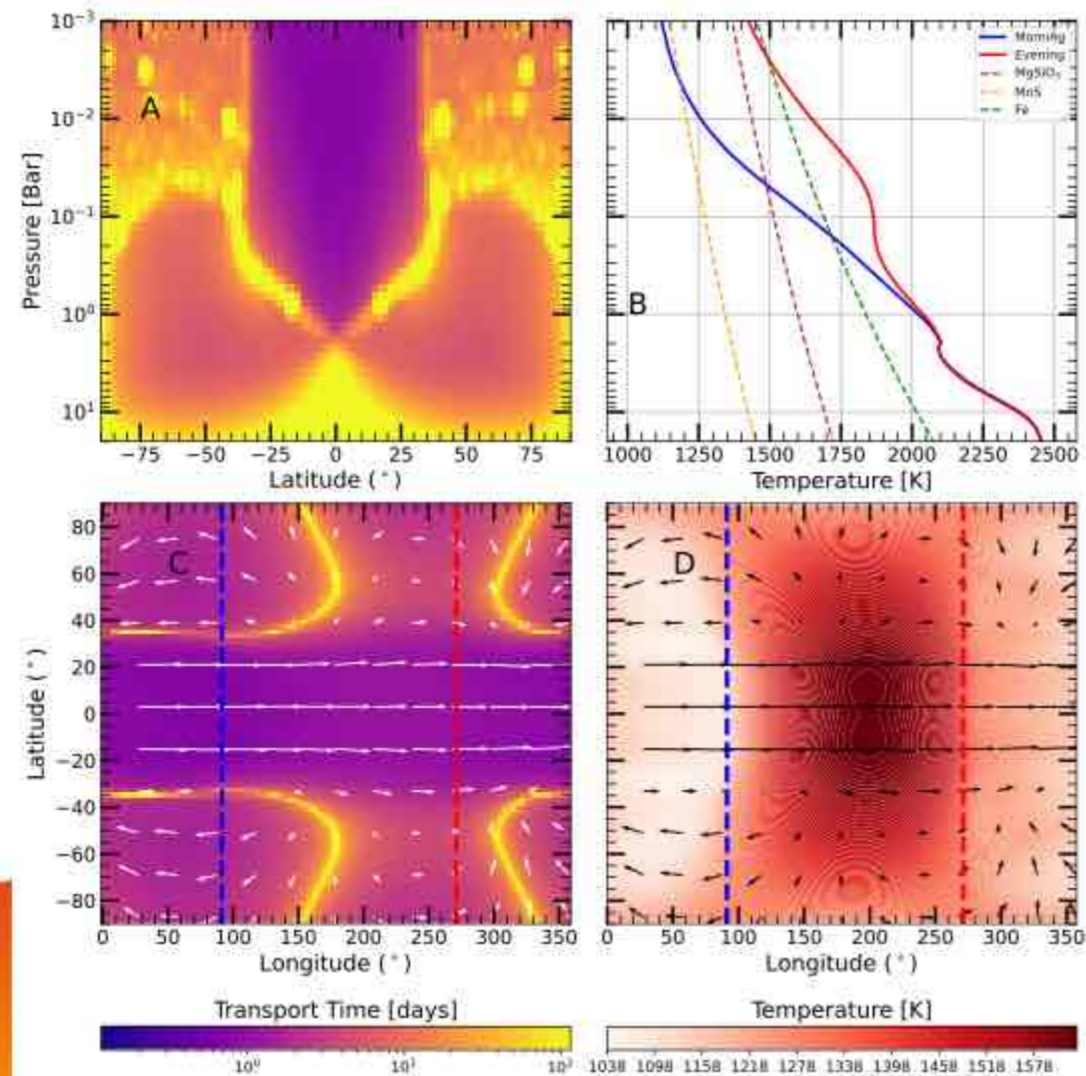

WASP-94Ab

PHOTO/THERMOCHEMICAL MODELLING



+

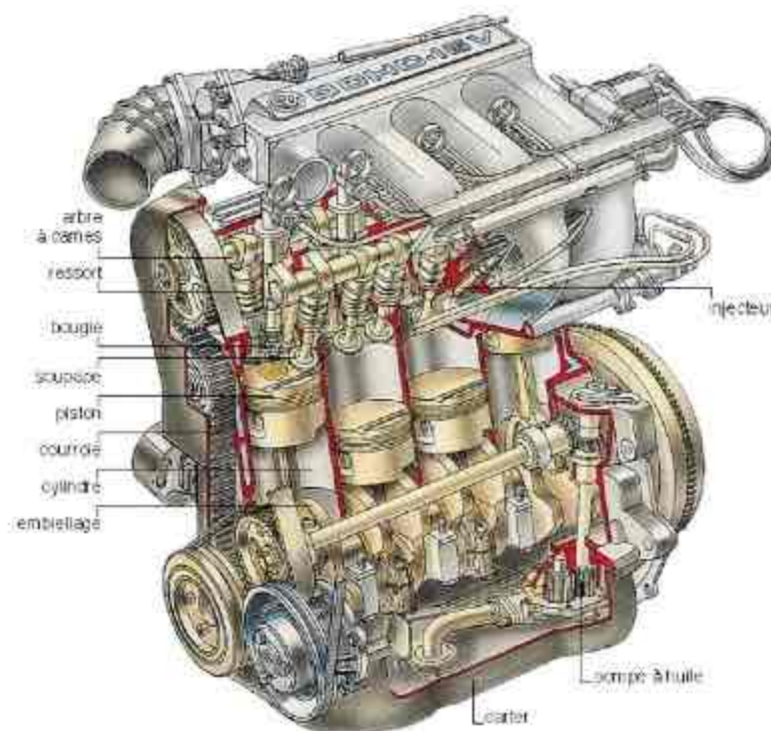

$C_0-C_2 / C_0-C_6 + NO_x$
+ PAHs + organic soots

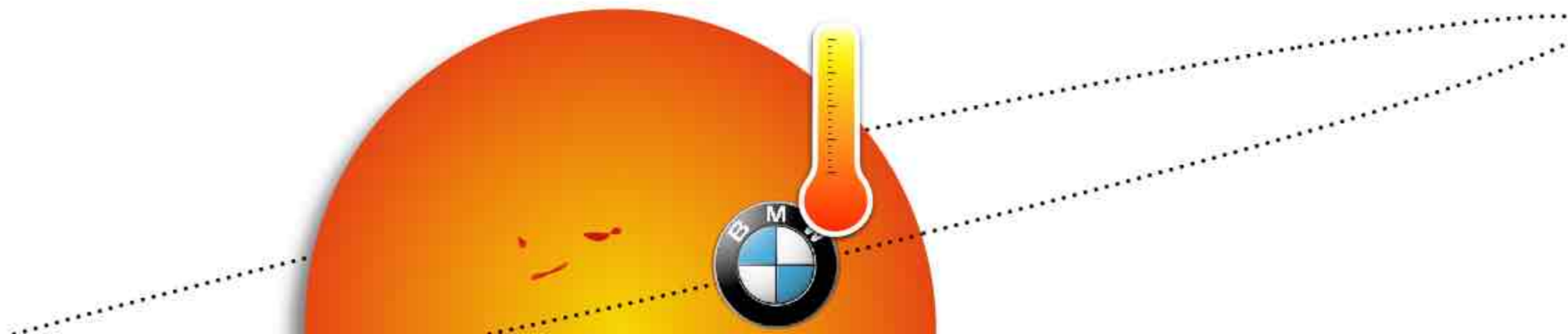

(EXO)CLIMATE SIMULATIONS

Met Office Unified Model

(Chemistry)



Mak et al., under review

Mei-Ting (Martha) Mak



Haze

Asymmetrical haze distribution

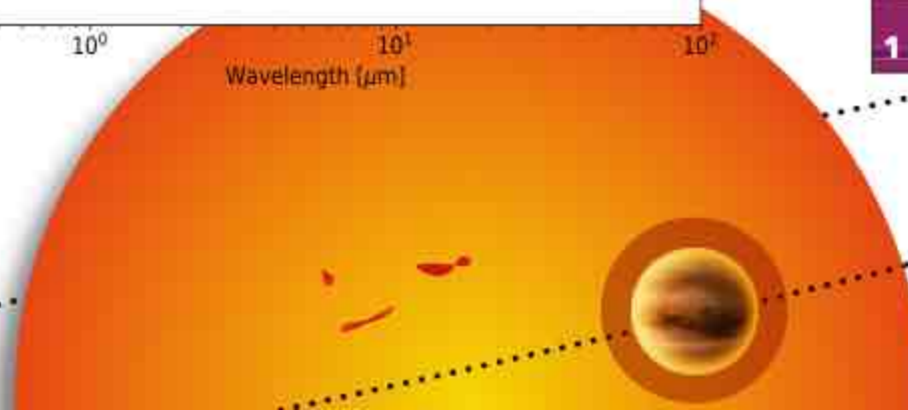
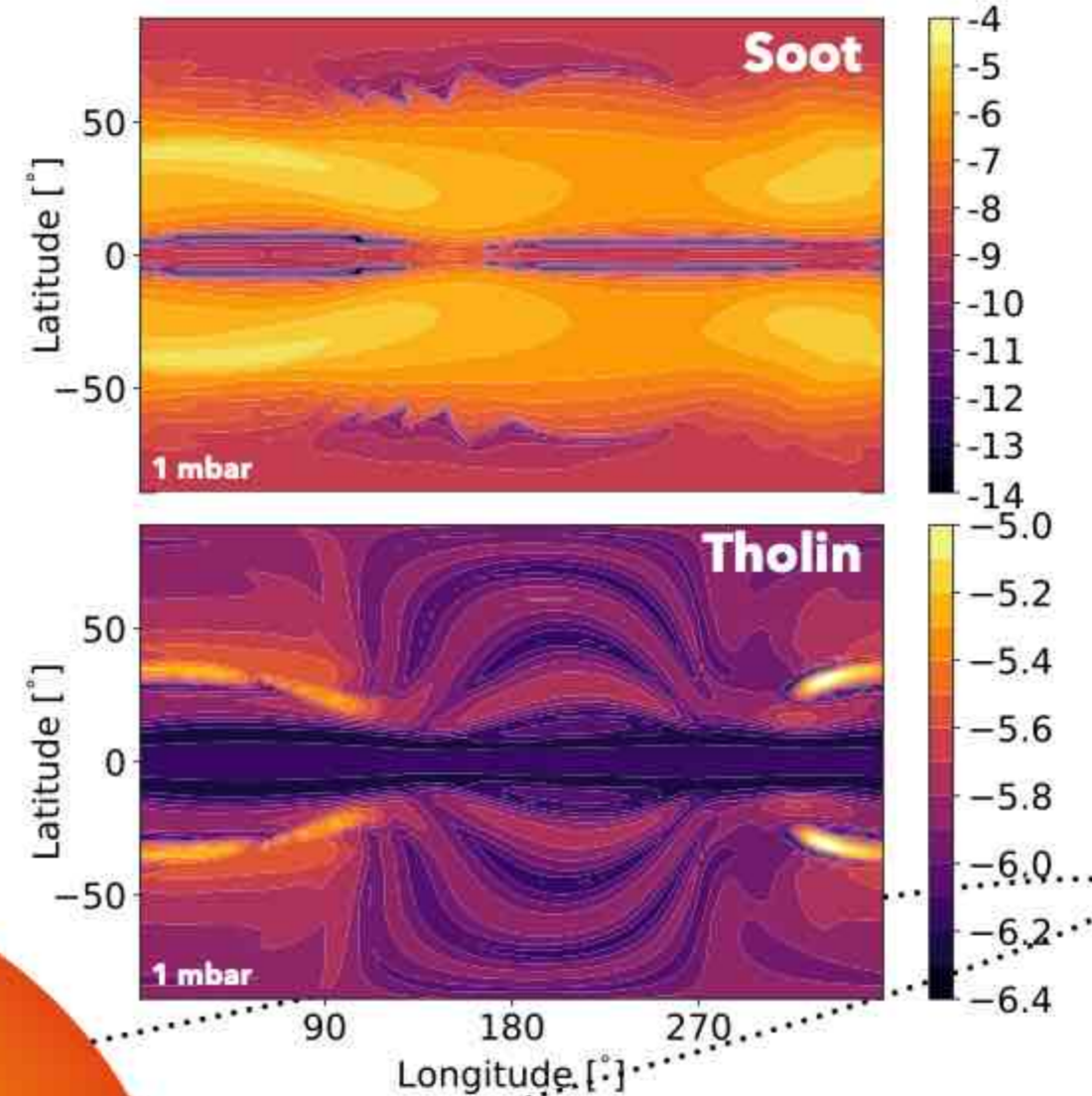
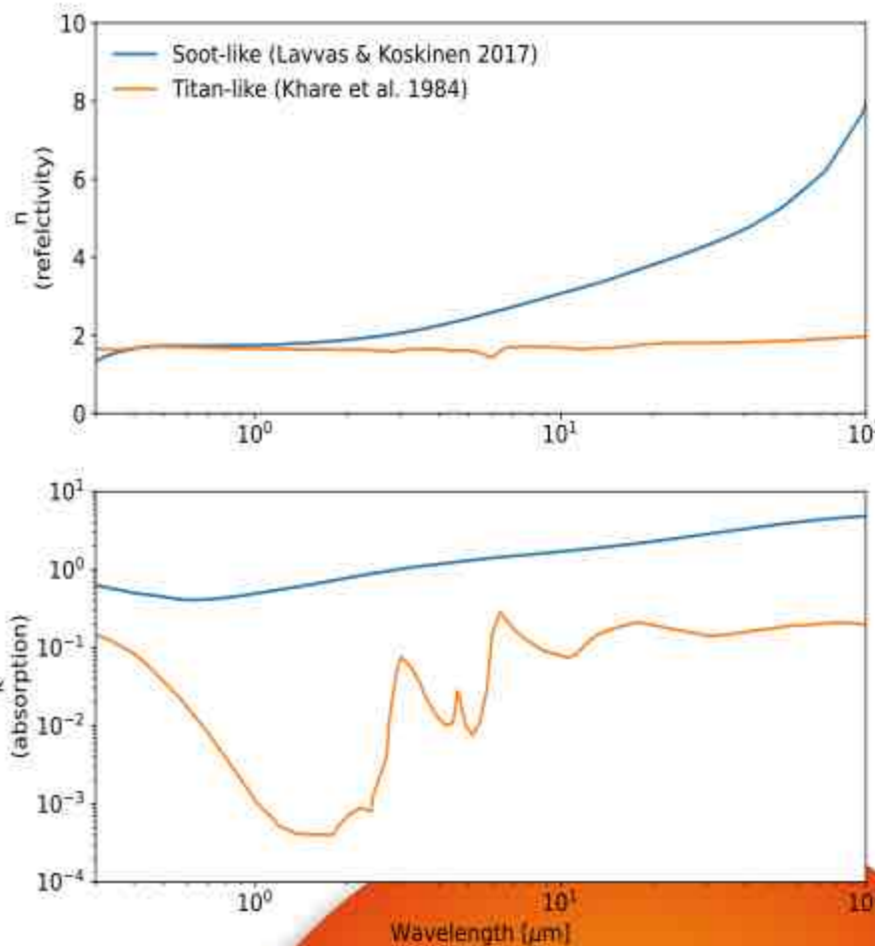

HD189733b

(EXO)CLIMATE SIMULATIONS

Met Office Unified Model

(Chemistry)



Mak et al., under review

Mei-Ting (Martha) Mak



Haze

Asymmetrical haze distribution

Haze trapped over nightside vortices

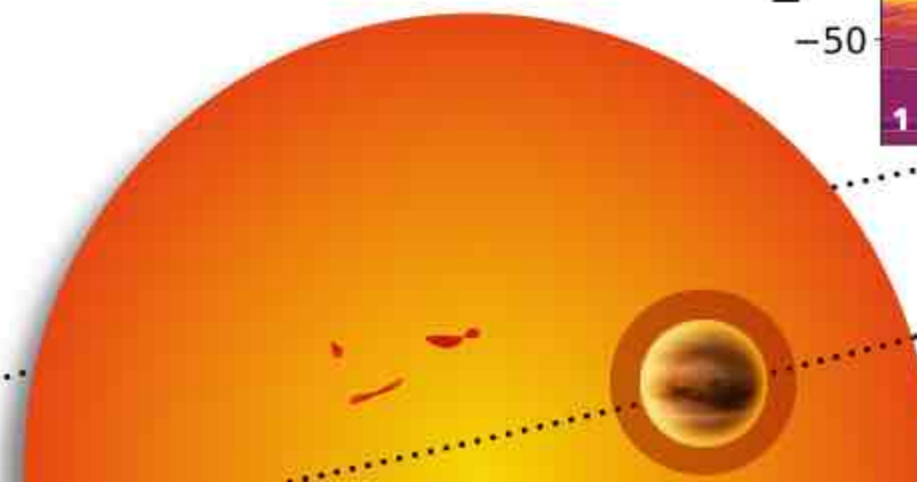
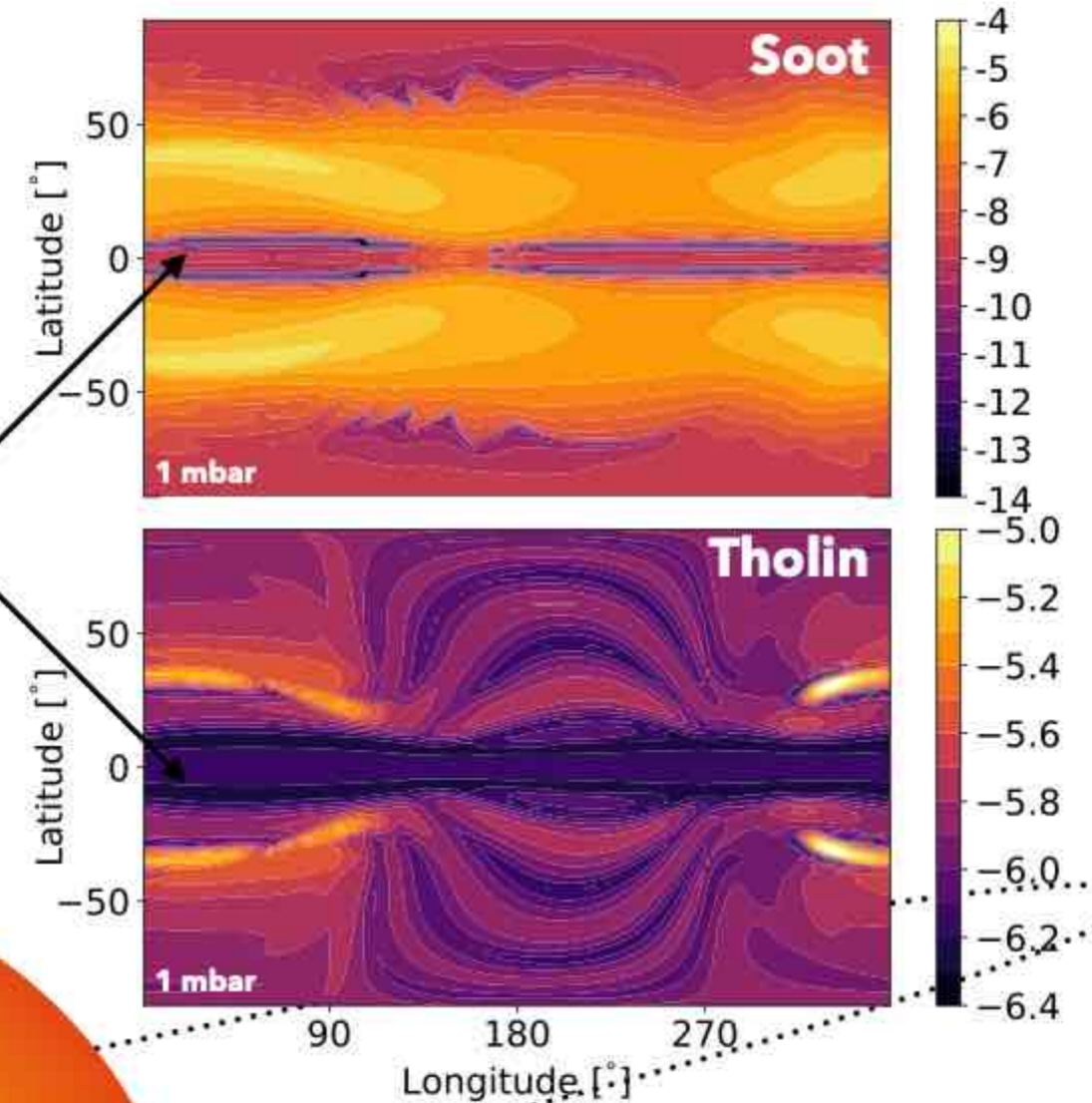

HD189733b

(EXO)CLIMATE SIMULATIONS

Met Office Unified Model

(Chemistry)



Mak et al., under review

Mei-Ting (Martha) Mak



Haze

Asymmetrical haze distribution

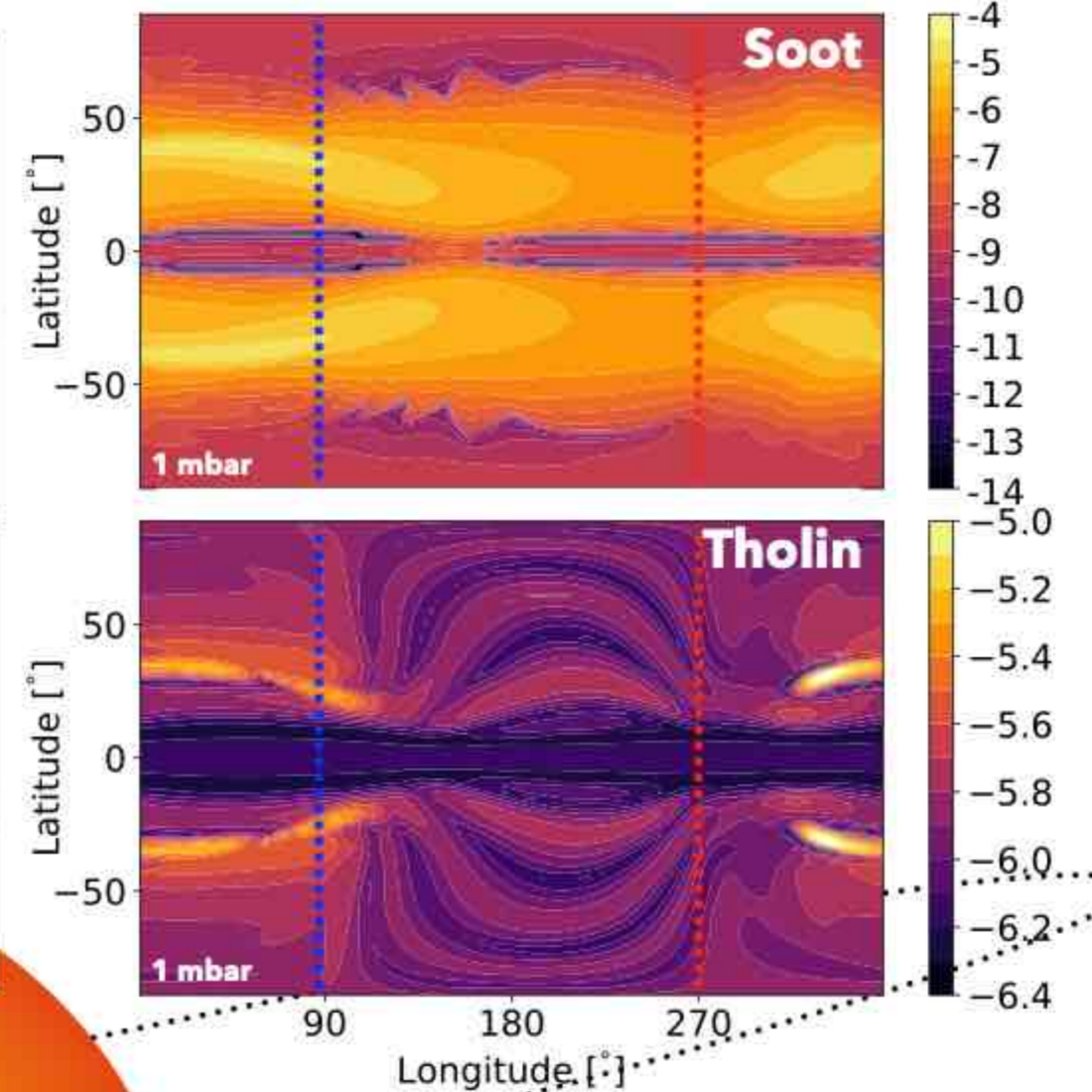
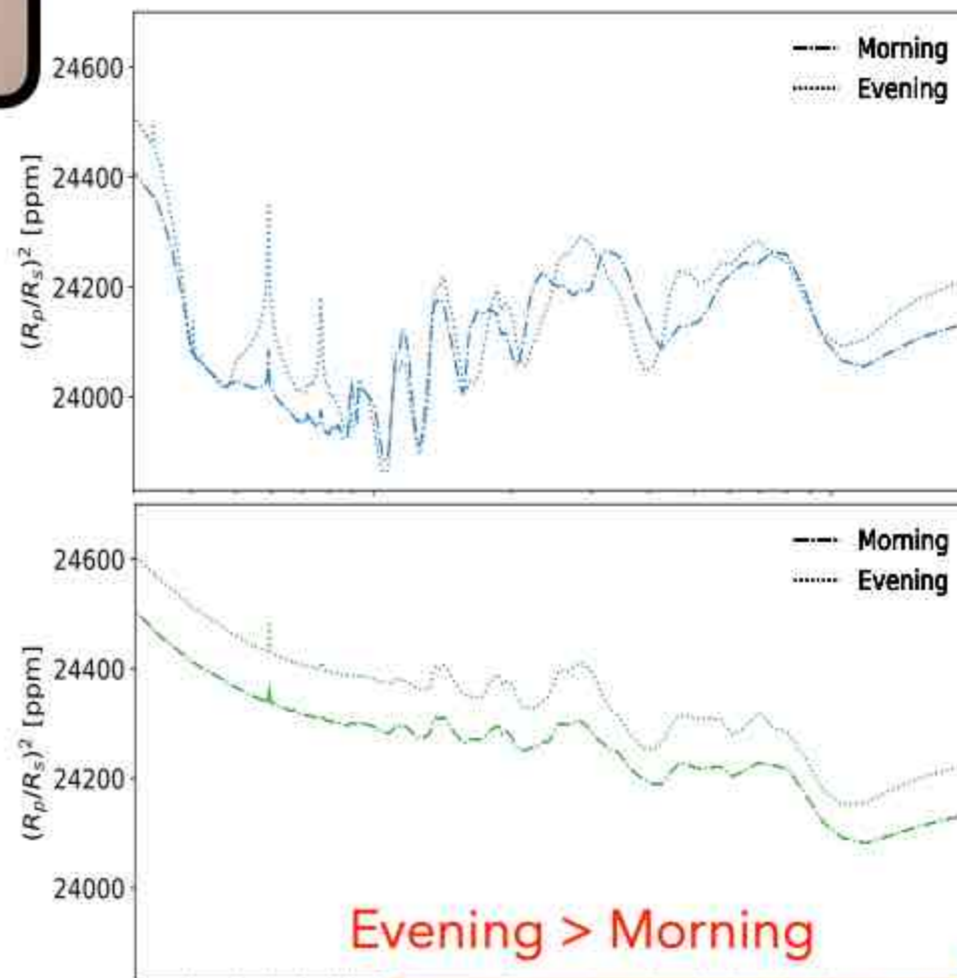

HD189733b

(EXO)CLIMATE SIMULATIONS

Met Office Unified Model

(Chemistry)



Mak et al., under review

Mei-Ting (Martha) Mak



Haze

Asymmetrical haze distribution

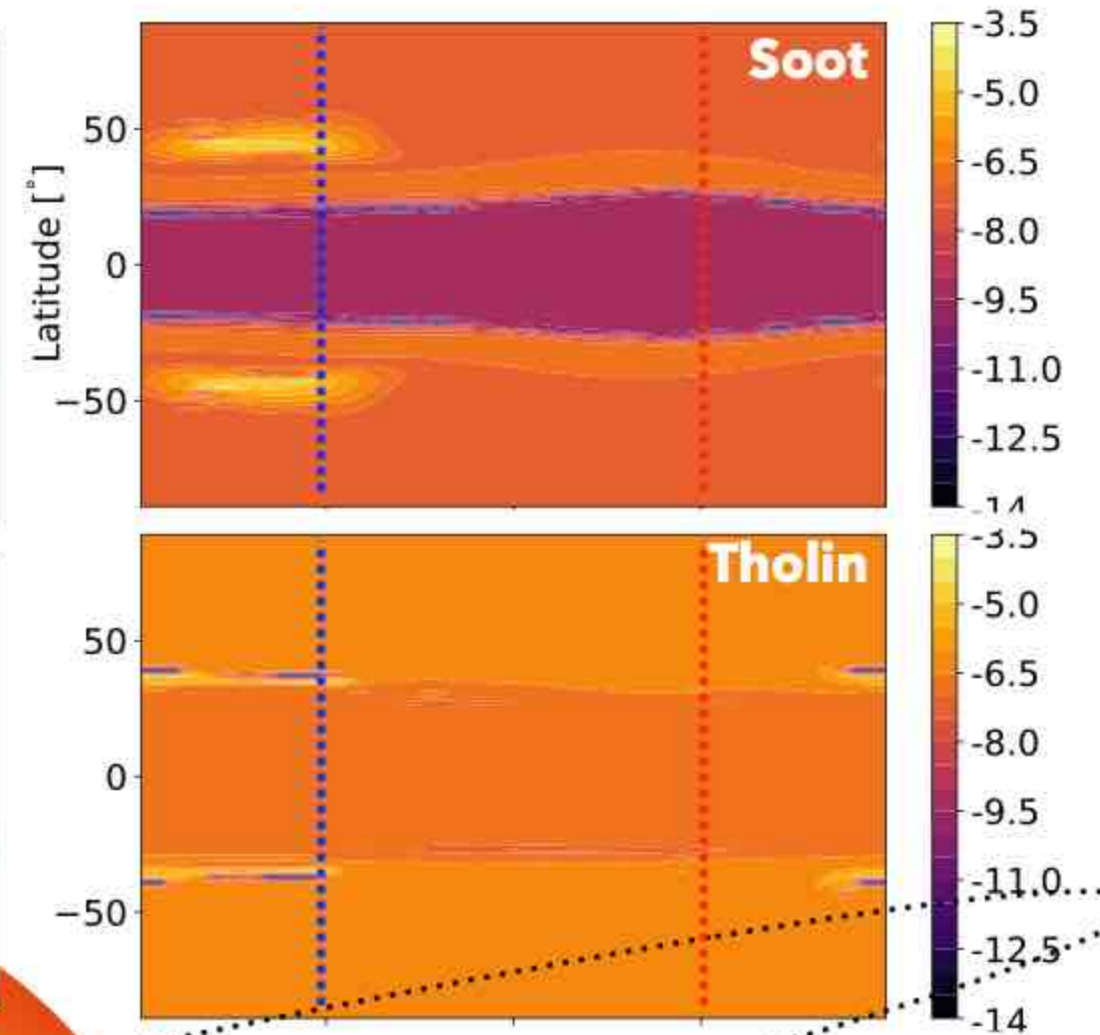
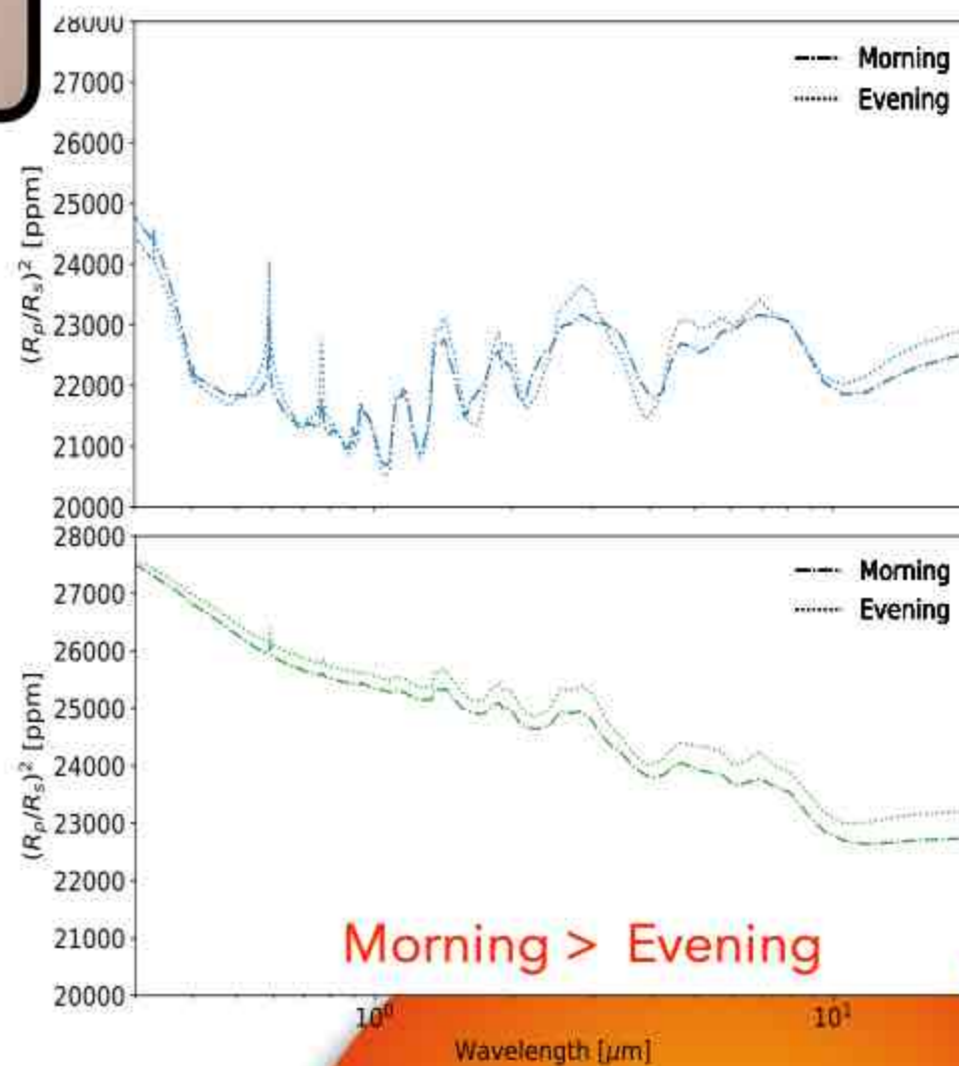

WASP-39 b

PHOTO/THERMOCHEMICAL MODELLING



+

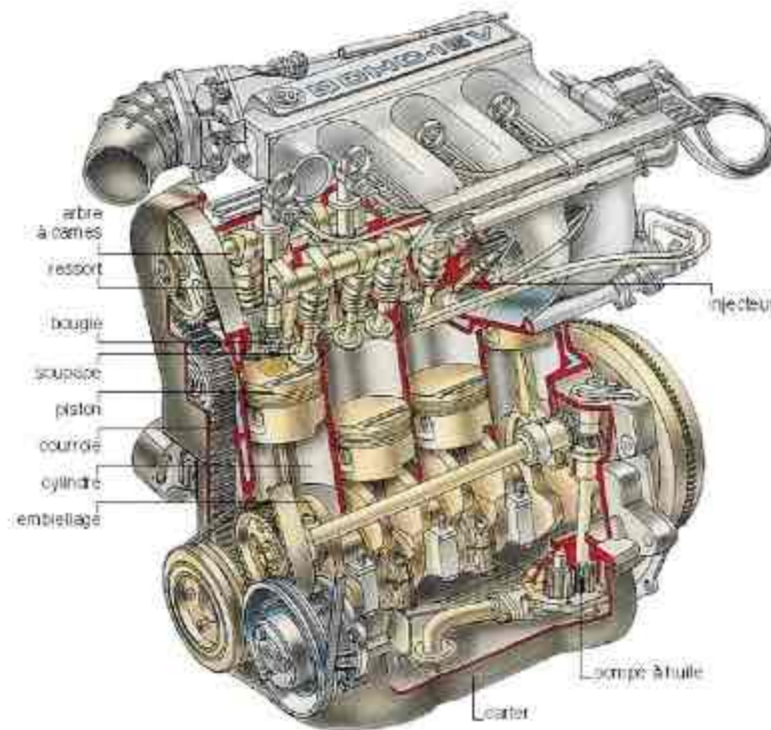

$C_0-C_2 / C_0-C_6 + NO_x$
+ PAHs + organic soots

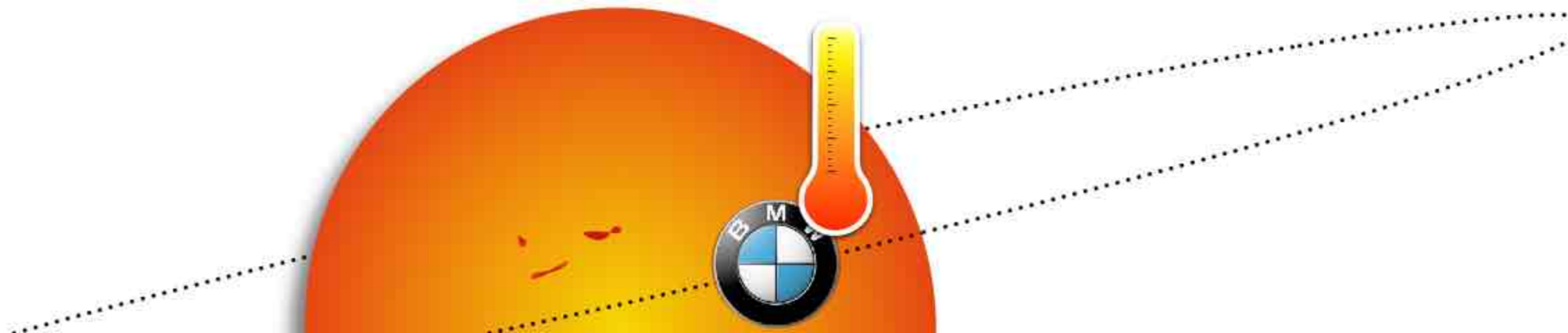

(EXO)CLIMATE SIMULATIONS

Met Office Unified Model

Chemistry



Adams et al., under review

Radiative Transfer



Photochemistry

Benchmarking photolysis rates

Sophia Adams

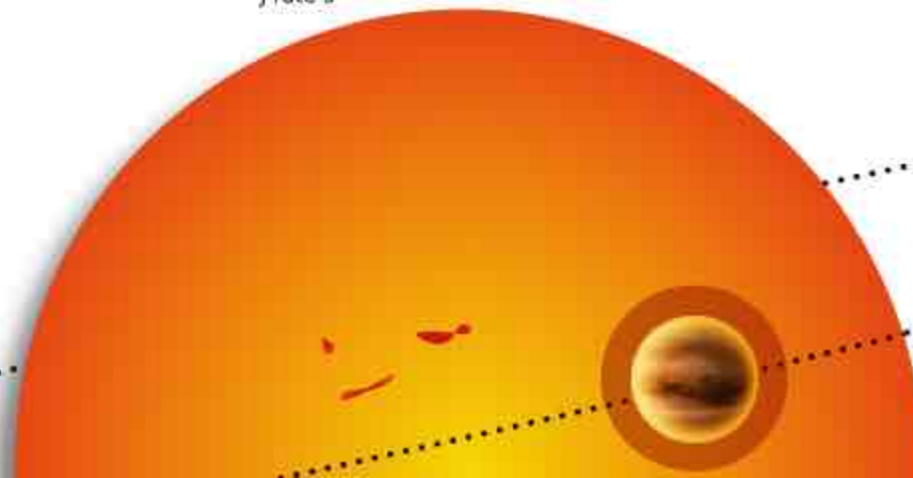
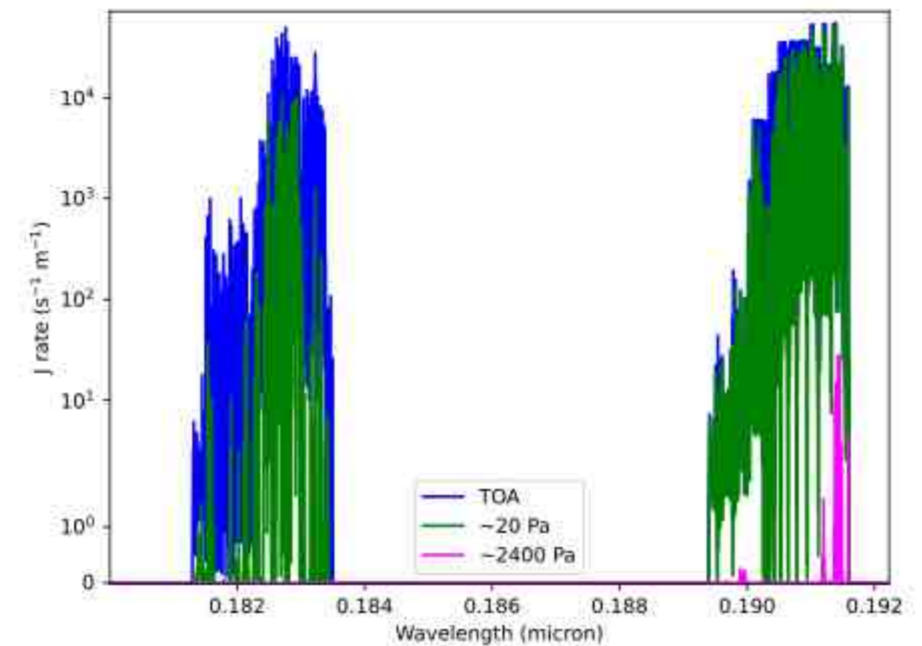
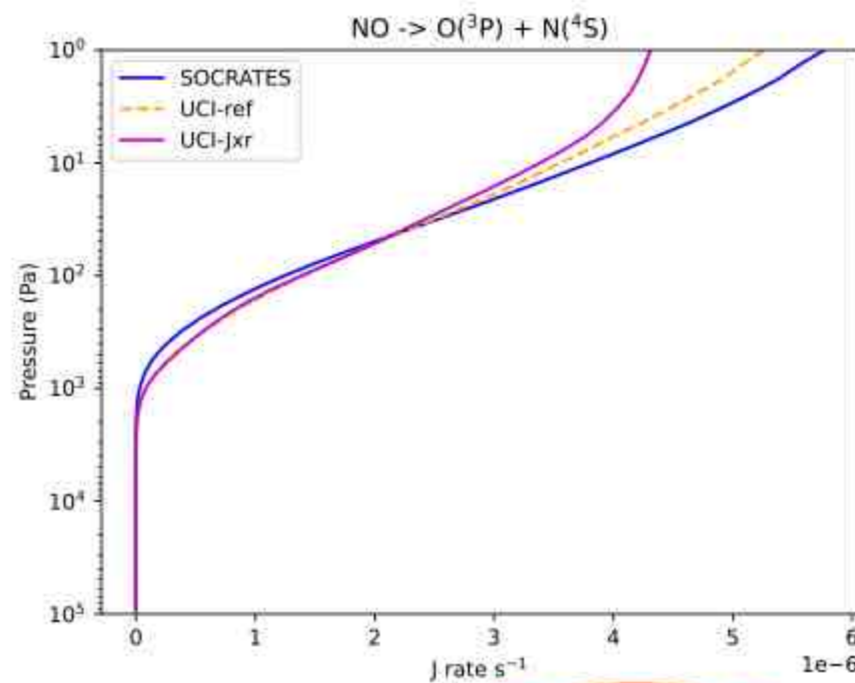

(EXO)CLIMATE SIMULATIONS

Met Office Unified Model

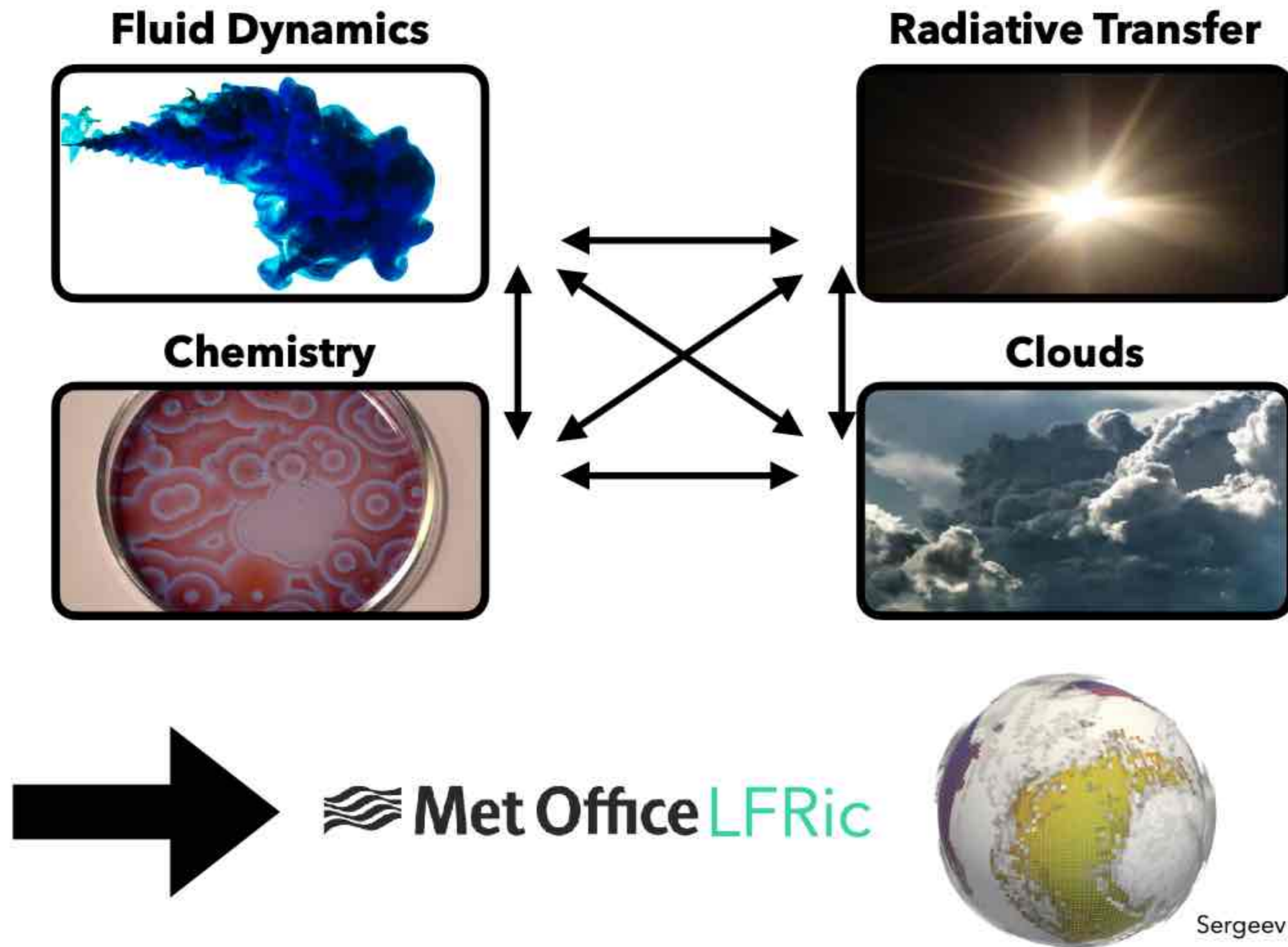

A 3D visualization of a planetary system. At the bottom center is a bright, glowing orange-yellow star. To the left is a large, detailed planet with blue oceans and white clouds. To the right, a series of smaller planets of various colors (blue, green, brown) are arranged in a line, receding into the distance. A dotted white line represents an orbital path or a sequence of frames. One of the smaller planets is shown in a cross-section, revealing a multi-layered internal structure with different colors representing different layers.

Take-home message:

(Exo)planets are 3D, so is their chemistry!